

Norton Notice

THE NEWSLETTER OF THE NORTHERN CALIFORNIA BRANCH

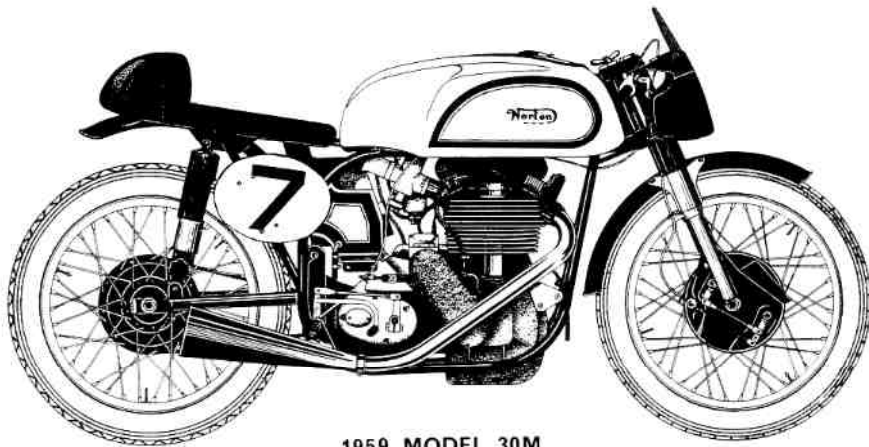

1959 MODEL 30M

Norton



NO. 80 DECEMBER 1984

Norton Notice

The Newsletter of The Northern California Branch



is published monthly by the NORTHERN CALIFORNIA BRANCH of the NORTON OWNERS CLUB. Its purpose is to inform and entertain members regarding all aspects of the Norton motorcycle, including history, technical advice, and preservation of the marque.

NORTON NOTICE is a reflection of its readership, who are encouraged to submit any article, technical tip, photograph (original or otherwise), as long as it is in good taste, so that other Norton enthusiasts may enjoy it. For Branch members who cannot attend club meetings or club rides, the NORTON NOTICE affords an opportunity to share experiences and information with the membership of the Branch, and to bring the Branch members closer together.

Deadline for items to be submitted for publication is the 21st of each month.

PRESIDENT

Scot Marburger
639 Kinglet Ave.
Livermore, Ca. 94550
(415) 455-8776

SECRETARY/TREASURER

Phil Radford
1020 Ellis Ave.
San Jose, Ca. 95125
(408) 293-4548

NORTON NOTICE EDITOR

Michael Heth
2503 Gough
San Francisco, Ca. 94123
(Mail in advertisements;
do not call them in!)

V.P./RIDE ORGANIZER

Gene Austin
985 E. Grant Pl.
San Mateo, Ca. 94402
(415) 573-9559

RECORDING SECRETARIES

Tom Horton
250 Curtner Ave. #6
Palo Alto, Ca. 94306
and
Harry Bunting
1401 Gilmore St.
Mountain View, Ca. 94040

PARAPHERNALIA

Tom Borman
2600 Belmont Canyon Rd.
Belmont, Ca. 94002

MEMBERSHIP IN THE NORTHERN CALIFORNIA BRANCH OF THE NORTON OWNERS CLUB IS AVAILABLE FOR \$25.00 PER YEAR.

MEMBERSHIP DUES ARE PAYABLE TO THE BRANCH SECRETARY/TREASURER, WHOSE NAME IS SHOWN ABOVE.

RENEWAL DUES ARE PAYABLE AT THE END OF THE INDIVIDUAL'S MEMBERSHIP YEAR, THAT MONTH BEING DESIGNATED BY THE LAST NUMBER OF THE INDIVIDUAL'S MEMBERSHIP NUMBER AS LOCATED ON THE MAILING LABEL OF THE NORTON NOTICE OR THE MEMBERSHIP CARD. FOR EXAMPLE, 745/2 DENOTES MEMBER NUMBER 745 WITH DUES EXPIRING ON THE 1st OF FEBRUARY.

ALL CHANGES OF ADDRESS SHOULD GO TO THE BRANCH SECRETARY/TREASURER, NOT THE NORTON NOTICE EDITOR.

Membership in the NORTHERN CALIFORNIA BRANCH of the NORTON OWNERS CLUB entitles a member to monthly issues of the NORTON NOTICE and bi-monthly issues of ROADHOLDER magazine, which is sent directly from England, keeping members informed of Norton owners' activities worldwide. Membership provides voting privileges at all NOC and Branch meetings, and allows one to purchase Norton spares directly from England, at significant savings, through the NOC Spares Program.

Subscription to the NORTON NOTICE only is available for \$15.00 per year. This does not include membership in the NORTHERN CALIFORNIA BRANCH of the NORTON OWNERS CLUB, nor does it afford any of the rights or privileges of membership in the NOC.



UPCOMING EVENTS

DECEMBER 9	10:00 A.M.	BAY BRIDGE TOLL PLAZA PARKING LOT	EAST BAY HILLS RIDE
DECEMBER 16	3:00 P.M.	RICK'S SWISS CHALET 4085 EL CAMINO WAY PALO ALTO	CHRISTMAS PARTY and ELECTION of OFFICERS

NOTICE: In the event of rain on the day of a club ride, the ride is automatically postponed one week. Also, riders should have plenty of oil and gasoline by the scheduled departure time and all personal problems should be taken care of. In other words....
FULL TANKS AND EMPTY BLADDERS!

TWISTIES

By the time you read this, it will be mid December and the Christmas Party will be only days away. If you want to attend the dinner part of the party to be held before the meeting you must contact me before Wednesday December 12 with \$7.00 for each dinner and let me know which of the menu selections you would care for (Sauerbraten or Chicken Cordon Bleu). After the dinner, we will hold a meeting, during which we will accept nominations for club offices and then vote on those offices. Since announcing that we were accepting nominations at the last monthly meeting, I have not received any response from any interested parties. To recap, the available offices and those currently running for re election are: Secretary Treasurer--Phil Radford, VP Ride Organizer--Nobody, President--Scot Marburger. We are also looking for a newsletter editor as mentioned in last month's column. Tom Mullen has indicated that he may be interested but has made no commitment yet. I will let it go that this is your club, if you enjoy the current level of performance of the newsletter, the rides, and the meetings, you should reelect those who have worked to make those things happen over the last year. Where there is no one to do the job (VP and Editor) I suggest you give some thought to volunteering your services so that the current high level of performance of the club might be maintained.

Your current ride organizer and president have been gazing into the the old polished headlamp shell and have seen several events on the horizon for next year. For starters, there will be a swap meet at TT Motors in Berkeley in January. This year the event drew about 100 interested people for parts trading and swapping lies. It was great fun, and I'd like to thank John Galivan and Mike Rettie for inviting us back. Look for additional details elsewhere in this Newsletter. We have also seen a joint Northern California and Southern California ride over the Memorial Day weekend. We plan to meet our southern neighbors in Morro Bay and kick tires and swill beer for the best part of the three day weekend. Best of all,

we WILL share the same campground, come Park Service or high water. Early summer should find us preparing for an overnight white water rafting trip down the American River. Art Sirota organized this trip a few years ago and it was a great success. Tentative plans for the annual rally call for a Sierra Nevada site complete with high altitude and twisty passes. Sprinkled in among these overnights will be our usual selection of one day peg scrapers for those with only limited time or questionable mechanical reliability.

Its only natural to look back at this year's events when planning for the next year, and it strikes me that this has been one of the most heavily "evented" years ever. The TT Motors swap meet, the EMA swap meet, the Morrow Bay overnights, the Gold Country overnights, the Big Sur annual rally, and my 10 day trip through the Sierra passes added up to a grand number of enjoyable miles. Club rides through the delta, the wine country, along the coast, the foothills, and coast ranges added more good times. Best of all, I feel the club is finally on the road to being a rider's and wrencher's club, and moving away from all the political turmoil that clouded years past. With the continued support of the membership and a strong core of club officers, I see another banner year in the making.

Happy Trails

Scot

VIBRATIONS

Welcome to the club the following new members:

John Cecil	Sunnyvale, ca.
Kelly Shane	Truckee, Ca.
Jonathan Gutoff	San Carlos, Ca.

Deposits are coming in nicely for the 1985 NOC calendar. This branch has ordered 50 copies from England. TT Motors in Berkeley have already taken 10, thus leaving 40 to go to branch members. Cost is \$6 each plus \$1 if you want it mailed to you. Please send monies to me if you want to reserve one or more for yourself, (checks made payable to the Norton Owners Club). Don't delay it's later than you think!

If you hadn't noticed there was an announcement in Roadholder that the NOC has had to put up the membership dues for overseas members from £8.5 to £9. This is because they now have to pay VAT (purchase tax) on our dues paid to them. But now the good news. It won't affect the amount you pay. The branch funds are in reasonably sound shape, enough to withstand the increase without passing it on to you, the member. The favorable exchange rate between the U.S. dollars and the British pound helps. A sound treasury is possible when everyone renews their membership on time, nudge, nudge you know who you aren't.

The forthcoming Christmas party at Rick's on Sunday, December 16th looks like being a lot of fun. If you wish to partake in the branch sponsored meal, send your \$7 to Scot Marburger (money bags II), Who needs to know by the 12th of December how many are wanting a meal. After eating, the December meeting will take place (approx. 7p.m.), and the festivities can begin. If you don't usually attend meetings please try to make this one and show your support for the club.

On the white branch membership form there is a selection for you the member to write your suggestions, ideas, etc, for the better running of the club. Please use this if you have a mind to. Your words are not ignored and most comments are passed along to the relevant officers of the branch for consideration. Sample #1, a lot of members ask that the monthly meetings be moved from their present locations to somewhere closer to where they live, preferably the end of their street. However this usually requires a lot of leg work by the President to find a suitable venue. So if you know of a good place to meet near you that

- A) doesn't dislike motorcycles or their owners
- B) serves beer (and maybe food also)
- C) has adequate parking
- D) separate meeting room
- E) isn't a million miles from the Bay Area then let us know.

Sample #2, How about making a club ride around where I live so that I can play too. Once again if you have a favorite ride (bring her along) that you think would be suitable and fun for one of our monthly jaunts, please submit it to one of the officers of the club together with a map and relevant details so that we can find new areas to ride the Nortons that we own.

Please don't try to order paraphernalia listed on the NOC triplicate membership form. The prices are in Pounds and it is impracticable for me to order items individually and impossible to work out the correct postage from England and convert it to dollars, etc. This branch does have a stock of paraphernalia but not all of it listed on the NOC form and in Roadholder. If we don't have what you want, you will have to purchase them yourselves direct from England. However if there is enough demand for a certain item we don't stock let our paraphernalia officer know, then we will get it.

8 Nortons, 2 Beemers and one trumpet attended the branch ride around the Carmel Valley loop on Sunday Nov. 18th. It turned out to be a dry and sunny day after some heavy rain on the Saturday. Everyone had brought along their rain gear so that guaranteed a dry day (must be a new Murphy's Law).

Our farthest flung fan of the Notice must be Chris Richardson who lives in So. Wales, Great Britain. He is an NOC member and receives the Notice each month. He has asked me to let all members of this branch know of a service he would like to give you.

Phil Radford

Dear Noccers,

My name is Chris Richardson, a member of the NCNOC for about 5 years before being amended to a subscriber of the Notice and sadly living in the U.K. and not able to enjoy your club life, to me more preferable to the English one. I have met a few of you on my visits to California and made notable friendships with Phil Radford (a good Englishman!), Art Sirota, and Tim Coburn, so ask them if the offer i am about to make is a genuine one.

I would be happy to offer a search service to members looking for Parts, Books, in fact anything to do with Nortons, or motorcycles in general, to cover my costs I would have to charge a fee of £10 sterling at least for postage and telephone charges etc. Anyone interested should write to me at the address below, enclosing minimum £10 sterling Barclays Bank Draft or check or sterling check from any British Bank. I have to insist on this because banks charge too much to change small amounts of dollars even with

the favorable exchange rate. Any money left out of this fee would be returned if I find the part easily (i.e. I don't have to spend too much searching for it), or I can advise you if the search is not successful and ask if you want me to keep on searching for you. I am in contact with a guy who can rebuild Smiths speedometers and Rev counters and can offer newly rebuilt Chronometric ones too, at a good price. Also I have a contact for Lucas switches, the hard to get kind for early bikes and Dommies etc. often these switches can be altered if the correct part for your is not available and a similar switch is (they can be modified simply to increase the number of contacts or the number of switch positions. And for example turn a lighting switch into a combined Ign. and Lights switch. I have done this on my own bikes). Also some pattern switches are available and you have the choice of genuine or pattern, as available.

I have the original Manx catalogue page used in "Roy Bacon's book NORTON SINGLES" page 97, it's multi colored and not black and white as in the book. If there is enough interest, I plan to have copies made and laminated and permanently sealed between two sheets of clear acrylic plastic about 2.5 m.m. thick and virtually shatterproof. These would be ideal to hang in the home or workshop, to frame or be drilled and fixed with screws. The original is 8X10" but could be enlarged as printing is necessary of the original, any ideas on size is welcome but all would have to be the same size. Also I would like to do an enlarged version of the UNAPPOACHABLE NORTON decal in the same manner. What about the club logo? individuals can write to me or people can get together at club meets and discuss it. I have a variety of prints and photos which can be done this way and one offs may be possible if you have something you'd like done this way. As I am not a business I cannot avoid U.K. tax at the moment and it may be better to send things privately i.e. as gifts, let me know of any problems with U.S. customs, would you have to pay a tax? etc. The doolar/pound exchange rate is very good to you now so it can pay to buy British (perhaps I'll get a Queen's Award for Exports for that statement). To make it cost effective I would have a number made so anyone interested, please let me know.

Sometimes parts need be bought when I come across them or may go to someone else. If you are desperate for a part send what you think or want to pay for it (used parts mainly) and I'll try and get it, if not desperate search fee only, be realistic, if I get your part I'll advise shipping cost. Anything from small parts to bikes can be searched for.

Write to:

Chris Richardson
106 Taff Embankment
Cardiff CPI 7BH
United Kingdom
(Enclose fee in Sterling)

Information required:

Make, Model, Year, Part Wanted, Part Number, if available.

If you have a parts book send a photo copy of the relevant page, the part is on abd any plate drawing. Or a photograph of a part or a bike if you have one (this will make sure we both know what is required). Books: Title, Author, Publisher, Year of Publication. (I have a contact who runs an out of print book search and it's free, but with a minimum fee for each book, offered or found, it was £5 but may have gone up since I last spoke to him some time ago). I WANT TO STRESS THIS IS NOT A BUSINESS PROJECT ON MY PART, BUT A PERSONAL SERVICE TO NCNOC MEMBERS. NO TRADE OR DEALERS ARE ACCEPTED ON THESE TERMS, THOUGH A SERVICE CAN BE PROVIDED TO GENUINE DEALERS WHO ADVERTISE IN THE NORTON NOTICE AND A SMALL PERCENTAGE FEE PAID TO CLUB FUNDS. INCLUDE YOUR MEMBERSHIP NUMBER IN EACH LETTER, AND WRITE CLEARLY IN CAPITALS YOUR REQUIREMENTS, NAME, AND ADDRESS.

Chris Richardson

Several members have urged me to organize another rafting trip similar to the one that we had a couple of years ago, so I've talked to the owner of the rafts and things are looking very good. The price is \$50 for the weekend. Camping will be an additional \$2 per person. This will be B.Y.O.P. (bring your own food). We have several choices: either do it in May or June and go down either the Tuolumne River or the American River. The American River is the one we went down the last time and is supposed to have much better camping facilities. Please let me know if you are interested and if so, which are your preferences. This combination ride/rafting trip proved to be very popular and a lot of fun the last time we tried it. Everyone is encouraged to attend. Don't miss it!

Art Sirota (415) 327-3167

THE EXHAUST NOTE

Some things never change, once a flake, always a flake. I've, as you no doubt have surmised, flaked out on this last issue of the NN and it's late. I have a long list of excuses, but the real reason that I postponed the NN (postponed sounds pretty good, almost as if I planned it) is that there is an unwritten law that if you put out 12 consecutive issues of the NN on time (as I was about to do) and miss 12 consecutive club rides (as I have), the world will come to an end. So you see it was just an heroic move on my part to flake out, fate takes care of things like this. I do apologize to those who sent in timely information that is obviously old news, 11 out of 12 ain't bad.

Onward, Tom Mullen has indeed indicated to me that he may be able to cover the NN for the club next year. I have the blue pencil all polished up and ready to go. I'll forgive the oversight on the envelope, this time.

As a short note to the Murphy's Law comment by Phil in his column. That law does exist. When I was touring in Yellowstone 3 years ago it took me 3 days to figure out the weather. Each morning it was blue sky, white clouds and beautiful. About 12 it would start to get overcast. It would rain like a mutha' from 1 to 3 in the afternoon and then clear up by 4 and be beautiful the rest of the day. After getting soaked out on rides for two days we thought we had it all figured out. The fourth day as we watched it cloud up we got out our raingear and put it on. We had Rukka rainsuits (the blue, full length ones) on and our helmets and gloves and were walking around the different areas of the park and no rain. Finally as a trickle of sweat ran down my back from the heat some old cracker came up and asked me what the hell we were doing in the getups. I replied "ensuring that you have a nice dry day in the park!" If you wear raingear it won't rain.

WM



T-SHIRTS*T-SHIRTS***T-SHIRTS*****

NOC BIG N LOGO

	S	M	LG	XLG
BLACK	*	*	*	*
NAVY	*	*	*	*
YELLOW/BLACK	*	*	*	*
WHITE/BLACK		*	*	

BRANCH LOGO

	S	M	LG	XLG
T-SHIRTS	*	*	*	*
BASEBALL JERSEY		*	*	*

All branch logo t-shirts are white, baseball jerseys are white with blue sleeves.

All t-shirts are Hanes Beefy T's
 Prices : T-shirts (all) \$8.00
 : Baseball Jerseys \$9.50
 Pay by check made payable to the
 "Norton Owners Club"



PARAPHERNALIA

4 1/2" STICKER N.O.C.	\$1.00
2" STICKER N.O.C.	\$.50
2 1/2" X 3 1/2" N.O.C. STICKER (RED, WHITE, AND BLUE)	\$.75
N.O.C. KEYFOB	\$1.50
4 1/2" EMBROIDERED PATCH	\$2.50
LAPEL PIN, BRANCH LOGO	\$1.25
T-SHIRTS - N.O.C. AND BRANCH VARIOUS SIZES AND COLORS CALL OR WRITE FOR DETAILS	TOM BORMAN 2600 BELMONT CANYON ROAD BELMONT, CALIFORNIA 94002 (415) 595-1954

**NORTHERN CALIFORNIA BRANCH
 TOOL LOAN-OUT PROGRAM**

Get in touch with Harry Bunting if you need one or more of the following tools for working on your bike. A refundable deposit equal to the replacement value of the tool is required at the time you pick it up.

TOOL	DEPOSIT
Timing cover oil seal guide.....	\$ 5.00
rocker spindle puller.....	\$25.00
crankshaft sprocket puller.....	\$12.00
clutch spring tool.....	\$12.00
clutch locking tool.....	\$18.00
valve spring compressor.....	\$22.00
exhaust nut "C" spanner.....	\$10.00
timing pinion extractor.....	\$20.00

Harry Bunting (415) 968-2020
 1401 Gilmore St.
 Mountain View, Ca. 94040

2 ND ANNUAL

Norton
OWNERS CLUB

SWAP MEET

**NORTON PARTS, COMPLETE
BIKES, AND ACCESSORIES**

**SUNDAY, JANUARY 27, 1985
10 AM--4PM RAIN OR SHINE!**

AT

TT MOTORS
2800 ADELIN, BERKELEY, CA

LIMITED INDOOR DISPLAY SPACE AVAILABLE

**SPONSORED BY TT MOTORS AND
NORTHERN CALIFORNIA BRANCH
OF THE
NORTON OWNERS CLUB**

**CONTACT MIKE RETTIE AT TT MOTORS
FOR MORE INFORMATION**

**TT MOTORS WILL NOT BE OPEN FOR
BUSINESS DURING THE SWAP MEET**

MORE ON SPEEDO DRIVES

After reading Nick Wilts' article concerning surface hardening in the October NN, I asked Nick if he would do a Rockwell hardness test on each of the two gears from an unservicable Smiths speedo drive that I had lying about. Here are his findings.

"The small gear that drives/turns the speedo cable exhibits a hardness of 32-35 Rockwell C-scale. The teeth on the small gear show a higher hardness of approximately 50(RC). The gear seems to be made of high carbon steel, which may be easily hardened to approximately 55-60(RC)".

"The large gear is much softer in hardness (softness?). It's hardness is too soft to be measured on the C-scale, so it was tested with a lighter load on the A-scale. This resulted in a reading of 39-42 (RA). The material of this gear appears to be a very low carbon steel, but it may still be hardened up to approximately 25(RC)".

"Both gears could be further hardened as the material is not used up to it's greatest potential- planned obsolescence! This phenomenon is not rare. From the foregoing, it is apparent that the material in the two gears has not been heat treated to obtain maximum wear properties for the application".

Now that our suspicions are confirmed, what can we do when the softer gear, the large one, wears out? Up to this point I've been cannibalizing parts from different speedo drives that have become unservicable and combining the parts in hopes of getting a servicable unit. But the limiting factor seems to be the scarcity of servicable large gears. I've inquired as to the possibility of buying new large gears from England but that doesn't seem possible.

What are now available are large gears made of plastic. OK, control the snickers! Assuming that the only part that needs to be replaced is the large gear, you can now rebuild your speedo drive with a \$15.95 kit that is available from Raber's European Cycle Works in San Jose. The kit only includes one plastic gear and four rivets, items 5 and 8 in the accompanying drawing. I talked to Bob Raber about this kit and he said that he "inherited" the kits from a shop that he bought out. The kits had first been sold about a year ago and he has sold 10 in the last 5 months that he has been in business. Only one complaint has been heard in these 10 cases, but in that particular case the rivets had been improperly installed, which allowed the gear to move around inside the speedo housing. I bought one of the kits, which is only available in the 15:12 ratio used on Commandos and found the instruction sheet complete and easy to understand. The worst part was cleaning the old parts prior to installing the plastic gear. Now I'm waiting to see how long the plastic gear lasts.

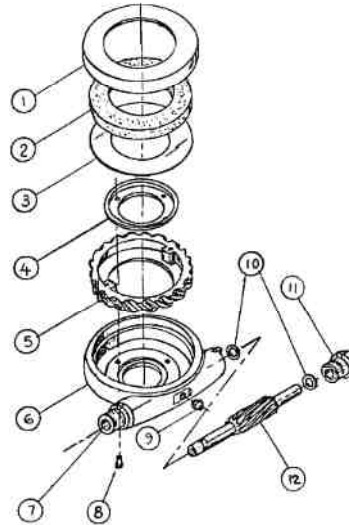

The grease interval with the plastic gear is still 5,000 miles, just like the stickerson new speedo drives. I personally think that's too long between lubrications (especially with a plastic gear), so I've been lubricating mine much more often than that. A little extra grease on the rear hub isn't nearly as bad as finding that your large gear just ate it.

Now for my little pitch, I have an incomplete speedo drive for my Dominator which is only missing item 4 (a dished washer) in the drawing. If you have one from an unservicable drive unit that you would like to sell, please let me know.

Gene Austin
985 E. Grant Place
San Mateo, Ca. 94402

CHRISTMAS CLEARANCE SALE

Treat yourself and your Norton to some goodies from the "House of Harvey" (yeech sounds like Macys)

- 1) Colin Lyster dual front disc conversion for Norton including wheel with alloy rim, including new pads and seals \$225
- 2) Good used connecting rods, ea. \$20
- 3) Fiberglass Interstate tank and seat combo, black/gold, no dings or rips \$115
- 4) Tranny housings ea. \$55
- 5) Stainless front fender for 850 new \$38
- 6) Good used valves, never ground ea. \$7
- 7) Lucas RF2 twin lead magneto, excl. \$65
- 8) Commando horn \$5
- 9) 750 and 850 heads all excl. ea. \$95
- 10) Central 'S' style oil tanks ea. \$15
- 11) Original factory shop manual \$15
- 12) Dunstall Decobel Silencers, excl. the good old style pr. \$45
- 13) Lucas turn signals "hard to find (right Phil?)" ea. \$10

15) 1974 Ducati Sport "mint" \$2275

16) Good used exhaust pipes-no dents or rust pr. \$20

17) any other Norton part you could possibly want \$Cheap

All of this stuff comes with the usual money back guarantee. Also I need a set of rear sets for a Commando- will actually pay cash for them! Best time to call is between 6&9 or weekends, but not after Dec. 23 please Harvey Loucks (408) 255-7356

FOR SALE

1) 750 head, circa 1970, bike had 3500 miles on it when the bottom end blew, head is perfect. Needs light work. \$100 or B.O.

2) 750 Gearbox, from same bike. Disassembled (the way you want it anyway), needs some parts, light rust on some parts, but good all around. 80% there, cases are excellent and have been beadblasted \$125 or B.O.

3) Roadster tank and sidecovers, factory Candy Apple Red (1975) fits all, very good condition, paint is not perfect but more than acceptable, \$75 or B.O.

Michael Heth (415) 441-2655 Leave message

WANTED

Interstate Tank and Seat
Interpol fairing
Erik Jaderquist

FOR SALE

1957 BSA A-10 many extra parts, frames, motors, tanks, includes A-65 motor \$500

Erik Jaderquist
6683 View Acres Drive
Paradise, Ca. 95969
(916) 877-2118

WANTED

850 MKIII any condition, complete or a basket case. Will take engine, frame, or what have you for project bike Steve Thompson (408) 946-7225

Also, does anyone have a copy of the magazine article on the Ron Woods Nortons from the early seventies?

FOR SALE

1972 Norton Commando Interstate, 750 c.c. Combat engine, 21,000 miles

NEW
seat, grabrail, Koni shocks, drive chain and guard, halogen headlight, Boyer ignition, exhaust pipes, Roadster mufflers, diehard battery, rear brake shoes, center stand.

NEEDS
Pork tubes, minor transmission work, disc rotor turned, paint on left side cover, 20,000 mile maintenance.

INCLUDES
Shop manual, parts list, clutch spring tool, eclipse tank bag.

Will part with obsession for \$1400/B.O.
David Ogorzalek Days (415)896-0305
Eves (415)824-8055

FOR SALE

1958 Nomad 600c.c. and 1950 model 7. Nomad runs and the model 7 is in process of restoration. Also included in damned good deal are new Commando bits and pieces, will give details over phone. Must sell whole lot. Call after 5 p.m. \$900.

Tom Mullen (408) 978-1851

WANTED

Matchless chaincase for P-11 Scrambler, also seat, bashplate, other items. Will buy or trade some parts.

John Voss (901) 682-5973
778 Waring Rd.
Memphis, Tn. 38122

FOR SALE

- 1) Twin 32 m.m. Mikuni carb conversion complete \$25
- 2) Early Commando central oil tank \$15
- 3) Lucas headlight shell with ammeter \$15
- 4) Smiths Tachometer \$50
- 5) Clutch toll for Commando \$5

David Crader

WANTED

1) Roadholder front end, pre Featherbed. Either purchase or trade for my short Roadholder Featherbed forks.

2) Late 50's Lucas headlight shell with switch, ammeter, and speedo built in

3) Dynamo for 1957-58 Norton single

4) Front engine plates for pre Featherbed Norton single.

5) Chrome bolt on gas tank panels for 1957-58 Norton single.



David Crader (408) 295-4968 Home
(408) 736-7205 Work
1475 Derosé Way #157
San Jose Ca. 95126

The great "The Japs bought our company sale"
A friend of mine just lost his job because his company was bought and the policy is now "no loud eyes". Consequently his 1973 Norton Commando which was a good buy at \$1100 is now priced at \$850. Call for details, it's a good one.
Michael Heth 441-2655

FOR SALE

- 1) Crankcases for 1946 Model 18, \$10
- 2) New wiring harness and headlamp harness for 1972-74 Commando, \$40 for both
- 3) Fiberglass totebox with lockable lid, \$5
- 4) New Armours no-weld reverse cone silencers for Commando \$70 pair.

Art Sirota (415) 327-3167

<p style="text-align: center;"><i>Hall-Burdette</i> MOTORCYCLES</p> <p style="text-align: center;">Norton</p> <p style="text-align: center;"> MOTO GUZZI DUCATI</p> <p>We have been selling and servicing Nortons since 1948 and have a good supply of parts and accessories, both new and used. Our mechanic, Bob Bennett, has been repairing Nortons for over 20 years and is a recognized expert. Thor Berke, our parts manager, has a thorough familiarity with all Norton parts and accessories.</p> <p style="text-align: center;">2010 DEL PASO BLVD. SACRAMENTO, CALIFORNIA 95815 PHONE (916) 825-1797</p>	<p style="text-align: center;">RABER'S EUROPEAN CYCLE WORKS, INC. "Your source for parts and service" BSA <small>(the original)</small> TRIUMPH</p> <p style="text-align: center;">Norton</p> <p style="text-align: center;">DUCATI MOTO GUZZI</p> <p style="text-align: center;">the same old guys at the same old place...</p> <p>Over 60 years combined M/C knowledge... (Bill must be older than I thought)</p> <p>*****PARTS: Bob Raber SERVICE: Bill Mankins*****</p> <p style="text-align: center;">1615c ALMADEN ROAD (rear building) SAN JOSE, CALIFORNIA. 95125 (408) 998-4495</p>
<p>Norton Triumph LAMARCA DUCATI MOTO MORINI</p> <p style="text-align: center;">T.T. MOTORS</p> <p>Norton Owners - T.T. specializes in European motorcycles and offers complete parts, service, and machine shop for all the wonderful bikes we sell.</p> <p>Stop by and visit and check us out!</p> <ul style="list-style-type: none"> * Complete line of British tools * Manuals and spares for your Norton * Speed Equipment: <p>Megacycle and webcam camshafts Single Mikuni kits Exhaust port repair \$45 each Valve jobs and port work Cylinder boring and surfacing</p> <p>* 10% discount on all parts (except Lucas) to N.O.C. members</p> <p style="text-align: center;">2800 Adeline Street Berkeley, CA 94703 9 a.m. - 8 p.m. Tues. - Sat. 845-8235</p>	<p style="text-align: center;">TRIUMPH</p> <p>Norton MOTO GUZZI DUCATI</p> <p style="text-align: center;">MUNROE MOTORS, INC.</p> <p style="text-align: center;">MOTORCYCLES SALES - SERVICE - PARTS</p> <p>Munroe has three mechanics that are familiar with Nortons and have been for a number of years. We can replace exhaust ports with the head on the bike and don't know of anyone else who can. The job looks like original factory! Call for a quote on shop prices. We also have a good Norton parts supply.</p> <p style="text-align: center;"> MUNROE MOTORS INC.</p> <p style="text-align: center;">412 VALENCIA ST. SAN FRANCISCO 94103 PHONE 626-3496</p>