

Norton Notice

THE NEWSLETTER OF THE NORTHERN CALIFORNIA BRANCH

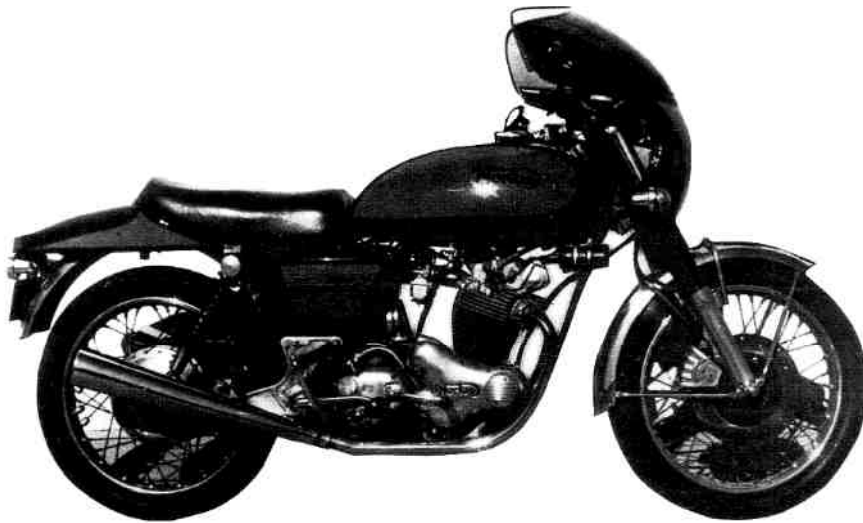

TOM BORMAN



NO. 81 JANUARY 1985

Norton Notice

The Newsletter of The Northern California Branch



is published monthly by the NORTHERN CALIFORNIA BRANCH of the NORTON OWNERS CLUB. Its purpose is to inform and entertain members regarding all aspects of the Norton motorcycle, including history, technical advice, and preservation of the marque.

NORTON NOTICE is a reflection of its readership, who are encouraged to submit any article, technical tip, photograph (original or otherwise), as long as it is in good taste, so that other Norton enthusiasts may enjoy it. For Branch members who cannot attend club meetings or club rides, the NORTON NOTICE affords an opportunity to share experiences and information with the membership of the Branch, and to bring the Branch members closer together.

Deadline for items to be submitted for publication is the 21st of each month.

PRESIDENT

Scott Marburger
639 Kinglet Ave.
Livermore, Ca. 94550
(415)455-8776

SECRETARY/TREASURER

Phil Radford
1020 Ellis Ave.
San Jose, Ca. 95125
(408) 293-4548

NORTON NOTICE EDITOR

Tom Mullen
1930 Almaden Rd. #45
San Jose, Ca. 95125
(Mail in advertisements;
do not call them in)

RIDE ORGANIZERS

Tom Dabel (408)272-0369
Mike Hansen (415)969-2489

PARAPHERNALIA

Tom Borman
2600 Belmont Canyon Rd.
Belmont, Ca. 94002

MEMBERSHIP IN THE NORTHERN CALIFORNIA BRANCH OF THE NORTON OWNERS CLUB IS AVAILABLE FOR \$25.00 PER YEAR.

MEMBERSHIP DUES ARE PAYABLE TO THE BRANCH SECRETARY/TREASURER, WHOSE NAME IS SHOWN ABOVE.

RENEWAL DUES ARE PAYABLE AT THE END OF THE INDIVIDUAL'S MEMBERSHIP YEAR, THAT MONTH BEING DESIGNATED BY THE LAST NUMBER OF THE INDIVIDUAL'S MEMBERSHIP NUMBER AS LOCATED ON THE MAILING LABEL OF THE NORTON NOTICE OR THE MEMBERSHIP CARD. FOR EXAMPLE, 745/2 DENOTES MEMBER NUMBER 745 WITH DUES EXPIRING ON THE 1st OF FEBRUARY.

ALL CHANGES OF ADDRESS SHOULD GO TO THE BRANCH SECRETARY/TREASURER, NOT THE NORTON NOTICE EDITOR.

Subscription to the NORTON NOTICE only is available for \$15.00 per year. This does not include membership in the NORTHERN CALIFORNIA BRANCH of the NORTON OWNERS CLUB, nor does it afford any of the rights or privileges of membership in the NOC.

Membership in the NORTHERN CALIFORNIA BRANCH of the NORTON OWNERS CLUB entitles a member to monthly issues of the NORTON NOTICE and bi-monthly issues of ROADHOLDER magazine, which is sent directly from England, keeping members informed of Norton owners' activities worldwide. Membership provides voting privileges at all NOC and Branch meetings, and allows one to purchase Norton spares directly from England, at significant savings, through the NOC Spares Program.

FEATURE BIKE

Here's an interesting combination of parts and ideas belonging to Tom Borman, the fellow who handles the branch's pins, badges, and T-shirts. The Interstate tank was picked for its usefull range and the Fastback seat and tail fairing plus the BMW /S fairing were picked for looks. Tom calls the bike his Inter-back. The fairing, tank, side covers and tail fairing were painted in bright red and black lacquer with a finish coat of Imron for protection by Scot Marburger.

The bike is a '74 850 with a basically stock engine, with the exception of an engine rebalance and a ported and flowed head. It has a Boyer transistorized ignition and a single Mikuni carburetor in this photo, although Tom has a pair of Amal MKII carbs that he plans to install very soon. Some other nice touches are the use of steel braided oil lines throughout, a drilled front brake, a stainless steel fork brace, adjustable Koni shocks with progressive rate 90/145 lb. springs, a Hella quartz 55/100 watt headlight (with the Lucas 3-phase alternator kit), and Albert bar end mirrors. Avon Roadrunner tires are installed front and rear. The bike has 47,000 miles on it and was totally rebuilt last winter.

UPCOMING EVENTS

January 10 7:30 P.M. Edinburgh Castle January meeting
950 Geary St.
San Francisco

January 20 10:00 A.M. Howard Johnsons January Mt. Hamilton ride
Intersection of No.1 St. and Highway
101, in San Jose.

January 27 10:00 A.M. T.T. Motors Swap Meet
Berkley

NOTICE! In the event of rain on the day of a club ride, the ride is automatically postponed one week. Also, riders should have plenty of oil and gasoline by the scheduled departure time and all personal problems should be taken care of. In other words....
FULL TANKS AND EMPTY BLADDERS!

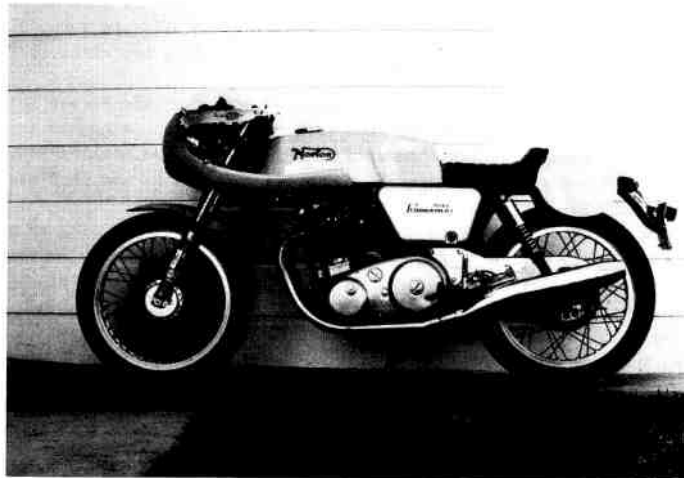

VIBRATIONS

Welcome to the club the following new members,

Charles De Rose	Cupertino, Calif.
Gregory Taylor	Santa Cruz, Calif.
Kevin Shapiro	Ignace, Ontario, Canada
Eugene Wellenstein	Kewaunee, Wisconsin
Steven Rolloff	San Francisco, Calif.
Dennis Morris	Sunol, Calif.
Andre Volant	San Bruno, Calif.
Nike Howard	Wappinger Falls, N.Y.

Following up on a subject I mentioned in the Notice a couple of months ago concerning the location of Norton frame numbers. I am grateful to Chris Richardson for pointing out to me a route by Ken Sprayson in Classic Motorcycle, He worked for Reynolds Tube Co. which back in the pre-commando days made the Featherbed frames for Norton. Apparently they used to stamp the month and year of manufacture on every frame before dispatching it to the Norton works. According to Mr. Sprayson it may take a bit of finding because they used very small stamps. It is to be found on the edge of one of the head-steady attachment lugs. Good hunting to all you Featherbed owners.

At the christmas party on Sunday, Dec. 16, we tried to present thank you awards to two dealers, who in the past have been very supportive of this branch, namely, John Gallivan of T.T. Motors in Berkley and Ed Brooks in San Jose. Unfortunately, Ed couldn't make it to the party, so John was the sole recipient of a solid oak plaque in the shape of the branch letter 'N'. In the center was a brass plate inscribed with our thanks for their support of the branch over the years. Ed was presented with his plaque a couple of days later at his shop in San Jose. Our thanks go to both John and Ed, and also to Art Sirota for the professional job he did of making the plaques and for donating his time to make them.

Also at the December gathering Gene Austin retired as ride coordinator and was thanked for the excellent job he had done of organizing the rides in 1984. In his place come Tom Dabel and Mike Hansen. So if you have any ideas for rides in 1985, let them know.

Retiring as well was our distinguished editor of the Norton Notice, Mike Heth. Our thanks go to him for his hard work in producing our newsletter for 12 issues and maintaining the high standards we enjoy in our own publication. Tom Mullen is the new guy, please note his address and send your ads, articles, tech tips, etc. to him now.

Scot Marburger carries on the excellent job he has been doing as president Tom Borman is still the person to get the paraphernalia from, and Harry Bunting continues as tool loan out officer. I am going down for the third time as membership secretary/treasurer, so keep those renewals coming in to me.

The 1985 N.O.C. calendars arrived just in time for members at the Christmas party to snap them up, and what a beauty this calendar has turned out to be. It is twice as big as last years, and better laid out too. Inside are great photographs of a wide range of Nortons. I have approx. 18 left. To reserve one, send me \$6 (checks made payable to the Nortons Owners Club), but if you need it mailed include an extra \$2 to cover postage, not \$1 as I have previously mentioned. I miscalculated the size of this sucker. Issue #117 was the last Roadholder newsletter from England. If you didn't receive it then let me know before I hand out the extras I have to prospective members as complimentaries.

Phil Radford

NEW

Officially speaking, the vaunted Blue Pencil has been passed on to me as the new Norton Notice editor. For those of you that doubt the existence of the Blue Pencil, see the picture at the bottom of column. I apologize for the shortness of this issue but due to the delay in picking up of the material from Mike Heth, which was entirely my fault, I am trying to get it out on time. I am also just learning to type, and being a two finger pecker...it takes me longer than normal to get things done. I promise next month will be better. I hope that someone notices that the type is a little larger. President Scot Marburger has not supplied a column for this month, so we look forward to reading it next month. Be sure to bring your wools and leave your plus fours at home on the ride up Mt. Hamilton. I will institute some changes in the Norton Notice and hopefully to the approval of all, or at least the majority. I am open to any suggestions as long as they are properly presented and are not physically impossible, after all, no one is that flexible.

See you on the mountain,
BEAR

Blue Pencil



T-SHIRTS****T-SHIRTS****T-SHIRTS****

NOC BIG N LOGO

	S	M	LG	XLG
BLACK	*	*	*	*
NAVY	*	*	*	*
YELLOW/BLACK	*	*	*	*
WHITE/BLACK		*	*	

BRANCH LOGO

	S	M	LG	XLG
T-SHIRTS	*	*	*	*
BASEBALL JERSEY		*	*	*

All branch logo t-shirts are white, baseball jerseys are white with blue sleeves.

All t-shirts are Hanes Beefy T's
Prices : T-shirts (all) \$8.00
 : Baseball Jerseys \$9.50
Pay by check made payable to the
"Norton Owners Club"



PARAPHERNALIA

4 1/2" STICKER N.O.C.	\$1.00
2" STICKER N.O.C.	\$.50
2 1/2" X 3 1/2" N.O.C. STICKER (RED, WHITE, AND BLUE)	\$.75
N.O.C. KEYFOB	\$1.50
4 1/2" EMBROIDERED PATCH	\$2.50
LAPEL PIN, BRANCH LOGO	\$1.25
T-SHIRTS - N.O.C. AND BRANCH VARIOUS SIZES AND COLORS CALL OR WRITE FOR DETAILS	TOM BORMAN 2600 BELMONT CANYON ROAD BELMONT, CALIFORNIA 94002 (415) 595-1954

NORTHERN CALIFORNIA BRANCH
TOOL LOAN-OUT PROGRAM

Get in touch with Harry Bunting if you need one or more of the following tools for working on your bike. A refundable deposit equal to the replacement value of the tool is required at the time you pick it up.

TOOL	DEPOSIT
timing cover oil seal guide.....	\$ 5.00
racker spindle puller.....	\$25.00
crankshaft sprocket puller.....	\$12.00
clutch spring tool.....	\$12.00
clutch locking tool.....	\$18.00
valve spring compressor.....	\$22.00
exhaust nut "6" spanner.....	\$10.00
timing pinion extractor.....	\$20.00

Harry Bunting (415) 968-2020
1401 Glimore St.
Mountain View, Ca. 94040

Norton

SERVICE BULLETIN

TRIUMPH NORTON INCORPORATED • P.O. BOX 275 • DUARTE, CALIFORNIA 91010

Number: 5/74
 Subject: Breaking-in
 Procedure
 Model: 850 Commando
 Date: 4/8/74

104

BREAKING - IN PROCEDURE

At the time of introduction of the 850 model Commando, the preferred engine lubricant recommendations were changed from multi-grade oils to heavy duty monogrades. (see service release N3/59)

The piston ring bedding pattern achieved with heavy duty monograde engine oils is ultimately superior than with multi-grades, and thus provides longer piston ring and cylinder bore life. However, it has been found that full bedding of the piston ring/cylinder wall combination is not fully achieved until 1200 miles have been completed, and hence normal economical oil consumption cannot be expected until that mileage.

The oils listed below are an example of the various brands available for use in the 850 Norton:

Monograde Oils

Castrol GP or HD 40	Torco Racing 40
Valvoline Racing 40	Kendel Racing 40
Shell--Aero Shell #80 40 weight	

Norton

SERVICE BULLETIN

TRIUMPH NORTON INCORPORATED • P.O. BOX 275 • DUARTE, CALIFORNIA 91010

Number: 6/74
 Subject: Zener Diode Heat
 Sink Compound
 Model: Norton Commandos
 Date: 4/8/74

105

CORRECT INSTALLATION OF ZENER DIODE

With the higher electrical output now being achieved from the motorcycle alternator, the zener diode is required to dissipate increased excess charging current than previously when running with no lighting load and a fully charged battery.

The existing zener diode (Lucas No. 49345) is perfectly capable of dealing with the additional load, provided the diode body is seated perfectly onto the footrest hanger plate, which functions as the heat sink.

When fitting or replacing a zener diode at any time, apply a thin smear of silicone compound to the mating surfaces to ensure full area heat transference.

Suitable silicone compounds specifically designed to meet this function are readily available from television repair shops. Two readily available compounds are:

1. G.E. Electronic Silicone Compound transistor Z-5 No. 8101
2. G.E. Silicone Compound G-640 or G-641

- 15) 1974 Ducati Sport "mint" \$2275
 - 16) Good used exhaust pipes-no dents or rust pr. \$20
 - 17) any other Norton part you could possibly want \$Cheap
- All of this stuff comes with the usual money back guarantee. Also I need a set of rear sets for a Commando- will actually pay cash for them! Best time to call is between 6:19 or weekends, but not after Dec. 23 please
- Harvey Loucks (408) 255-7356

WANTED

- 1) Roadholder front end, pre Featherbed. Either purchase or trade for my short Roadholder Featherbed forks.
- 2) Late 50's Lucas headlight shell with switch, ammeter, and speedo built in
- 3) Dynamo for 1957-58 Norton single
- 4) Front engine plates for pre Featherbed Norton single.
- 5) Chrome bolt on gas tank panels for 1957-58 Norton single.

David Crader (408) 295-4968 Home
(408) 736-7205 Work
1475 Derose Way #157
San Jose Ca. 95126

WANTED

Interstate Tank and Seat
Interpol fairing
Erik Jaderquist

FOR SALE

1957 BSA A-10 many extra parts, frames, motors, tanks, includes A-65 motor \$500

Erik Jaderquist
6683 View Acres Drive
Paradise, Ca. 95969
(916) 877-2118

WANTED

850 MXIII any condition, complete or a basket case. Will take engine, frame, or what have you for project bike Steve Thompson (408) 946-7225

Also, does anyone have a copy of the magazine article on the Ron Woods Nortons from the early seventies?

FOR SALE

1972 Norton Commando Interstate, 750 c.c. Combat engine, 21,000 miles

NEW

seat, grabrail, Koni shocks, drive chain and guard, halogen headlight, Boyer ignition, exhaust pipes, Roadster mufflers, diehard battery, rear brake shoes, center stand.

NEEDS

Fork tubes, minor transmission work, disc rotor turned, paint on left side cover, 20,000 mile maintenance.

INCLUDES

Shop manual, parts list, clutch spring tool, eclipse tank bag.

Will part with obsession for \$1400/B.O.
David Ogorzalek Days (415)896-0305
Eves (415)824-8055

January Sale:

ATLAS PARTS FOR SALE

- 1. Norton Atlas Slimline frame, straight, comes complete with swing-arm and rear shocks. \$130
- 2. 750 Atlas engine, number matches frame above. \$100
- 3. 650 SS Dominator engine, no pistons. \$80
- 4. Atlas tach and speedo gauges, both work, mounting plate, and light switch, complete unit only \$50
- 5. Atlas transmission, complete with sprocket and both levers. \$75
- 6. Norton bolt-on type rear wheel, WM2 rim, excellent chrome, and good tire. \$35
- 7. Dominator bolt-on 5/8 x 1/4" brake drum. \$15
- 8. Short Roadholder forks, complete with triple clamps. \$25
- 9. Atlas center stand. \$25
- 10. One set Atlas engine plates. \$15
- 11. One pair Atlas rider footpegs. \$15
- 12. Atlas gas tank, few dents. \$15
- 13. Pair Atlas primary chain cases. \$30
- 14. Atlas oil tank, complete with fittings. \$25
- 15. Atlas battery box and lid. \$25
- 16. Complete Atlas clutch, incl. plates. \$30
- 17. Norton SLS front wheels, cheap.
- 18. One pair high level left sided exhaust pipes. I'm not sure whether these fit an Atlas or Commando, but they're real long babies. \$25
- 19. I have some cylinders, heads, cranks, cases for 600 cc. Dominator engines.

COMMANDO PARTS FOR SALE

- 1. One pair rider footrests, complete with brake pedal. Good chrome. \$35
- 2. Front engine mount and rear transmission cradle. \$25
- 3. 850 seat, small tear. \$20
- 4. Commando seat, foam rubber inside, good shape. \$10
- 5. Lots of other odds and sods for the Commando, too numerous to list. Try me.

OTHERS

- 1. Mid 60's Triumph seat, newly recovered. \$45
 - 2. Chrome sissy bar and luggage rack. \$15
 - 3. 1962 BSA Rocket Gold Star, genuine example, new engine, needs some parts & work. Offers
- Call mornings and weekends
Phil Radford (408)293-4548

WANTED

Matchless chaincase for P-11 Scrambler, also seat, bashplate, other items. Will buy or trade some parts.

John Voss (901) 682-5973
778 Waring Rd.
Memphis, Tn. 38122

FOR SALE

- 1) Twin 32 m.m. Mikuni carb conversion complete \$25
- 2) Early Commando central oil tank \$15
- 3) Lucas headlight shell with ammeter \$15
- 4) Smiths Tachometer \$50
- 5) Clutch toll for Commando \$5

David Crader

A Service for enthusiasts

Our Service Department exists for one purpose . . . to help Norton enthusiasts with any problem at any time. The question of getting the best out of your machine can quickly be answered by Norton's team of experts.



NORTON MOTORS LIMITED, ASTON, BIRMINGHAM, 4

Parts © 84

ROCKER SPINDLE COVER PLATES

One piece machined aluminum plate replaces both original steel plates. Fits all twins. Stainless steel buttonhead allen bolts also available.

PLAIN FACE-SET OF 4	FINNED FACE-SET OF 4
As machined - \$ 20.00	As machined - \$ 27.00
Beadblasted - \$ 22.00	Beadblasted - \$ 29.00
Polished - \$ 24.00	Polished - \$ 31.00

STAINLESS STEEL BOLTS-SET OF 8 - \$ 4.00
(Measure old bolts, specify 1/2" or 3/4")

GASKETS (Best quality white Durable) SET OF 4 - \$ 1.00

Add \$3.00 shipping, specify US mail or UPS.
CHUCK GANANCE
P.O. BOX 14915, CINCINNATI, OHIO, USA 45214

FOR SALE

- 1) Crankcases for 1946 Model 18, \$10
- 2) New wiring harness and headlamp harness for 1972-74 Commando, \$40 for both
- 3) Fiberglass totebox with lockable lid, \$5
- 4) New Armours no-weld reverse cone silencers for Commando \$70 pair.

Art Sirota (415) 327-3167

CHRISTMAS CLEARANCE SALE

Treat yourself and your Norton to some goodies from the "House of Harvey" (yeech sounds like Macys)

- 1) Colin Lyster dual front disc conversion for Norton including wheel with alloy rim, including new pads and seals \$225
- 2) Good used connecting rods, ea. \$20
- 3) Fiberglass Interstate tank and seat combo, black/gold, no dings or rips \$115
- 4) Tranny housings ea. \$55
- 5) Stainless front fender for 850 new \$38
- 6) Good used valves, never ground ea. \$7
- 7) Lucas KP2 twin lead magneto, excl. \$65
- 8) Commando horn \$5
- 9) 750 and 850 heads all excl. ea. \$95
- 10) Central 'S' style oil tanks ea. \$15
- 11) Original factory shop manual \$15
- 12) Dunstall Decobel Silencers, excl. the good old style pr. \$45
- 13) Lucas turn signals "hard to find (right Phil?)" ea. \$10

PLATE J

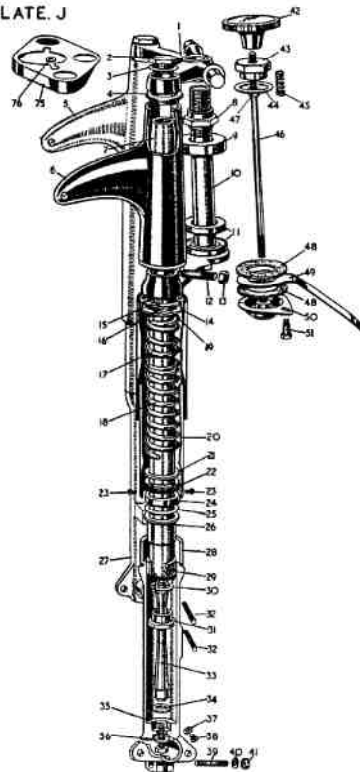

The great "The Japs bought our company sale" A friend of mine just lost his job because his company was bought and the policy is now "no loud eyes". Consequently his 1973 Norton Commando which was a good buy at \$1100 is now priced at \$850. Call for details, it's a good one.
Michael Heth 441-2655

2 ND ANNUAL

Norton
OWNERS CLUB

SWAP MEET

**NORTON PARTS, COMPLETE
BIKES, AND ACCESSORIES**

**SUNDAY, JANUARY 27, 1985
10 AM--4PM RAIN OR SHINE!**

AT

TT MOTORS
2800 ADELIN, BERKELEY, CA

LIMITED INDOOR DISPLAY SPACE AVAILABLE

SPONSORED BY TT MOTORS AND
NORTHERN CALIFORNIA BRANCH
OF THE
NORTON OWNERS CLUB

CONTACT MIKE RETTIE AT TT MOTORS
FOR MORE INFORMATION

TT MOTORS WILL NOT BE OPEN FOR
BUSINESS DURING THE SWAP MEET

Hall-Burdette

MOTORCYCLES

Norton
MOTO GUZZI**DUCATI**

We have been selling and servicing Nortons since 1948 and have a good supply of parts and accessories, both new and used. Our mechanic, Bob Bennett, has been repairing Nortons for over 20 years and is a recognized expert. Thor Berke, our parts manager, has a thorough familiarity with all Norton parts and accessories.

2010 DEL PABO BLVD.
SACRAMENTO, CALIFORNIA 95815
PHONE (916) 925-1797

RABER'S
EUROPEAN CYCLE WORKS, INC.
"Your source for parts and service"
BSA TRIUMPH

Norton

DUCATI MOTO GUZZI

the same old guys at the same old place...

Over 60 years combined M/C knowledge...
(Bill must be older than I thought)

*****PARTS: Bob Raber
SERVICE: Bill Mankins*****

1615c ALMADEN ROAD (rear building)
SAN JOSE, CALIFORNIA. 95125
(408) 998-4495

Norton
TRIUMPH
LAMBERTA
DUCATI
MOTO MORINI

**T.T.
MOTORS**

Norton Owners - T.T. specializes in European motorcycles and offers complete parts, service, and machine shop for all the wonderful bikes we sell.

Stop by and visit and check us out!

- * Complete line of British tools
- * Manuals and spares for your Norton
- * Speed Equipment:

Megacycle and webcam camshafts
Single Mikuni kits
Exhaust port repair \$45 each
Valve jobs and port work
Cylinder boring and surfacing

- * 10% discount on all parts (except Lucas) to N.O.C. members

2800 Adeline Street
Berkeley, CA 94703
9 a.m. - 6 p.m. Tues. - Sat. 845-8235

TRIUMPH
Norton MOTO GUZZI **DUCATI**
MUNROE MOTORS, INC.

MOTORCYCLES
SALES - SERVICE - PARTS

Munroe has three mechanics that are familiar with Nortons and have been for a number of years. We can replace exhaust ports with the head on the bike and don't know of anyone else who can. The job looks like original factory! Call for a quote on shop prices. We also have a good Norton parts supply.

MUNROE MOTORS

INC.
412 VALENCIA ST.
SAN FRANCISCO 94103
PHONE 626-3496