



Norton Notice



The Newsletter of the Norton Owners Club

No. 157

May 1991

750 ATLAS

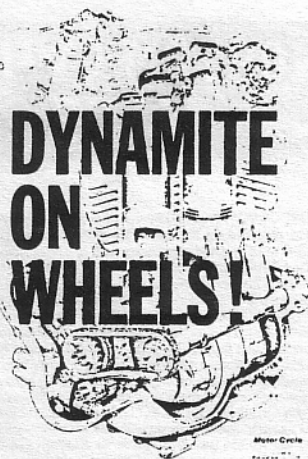
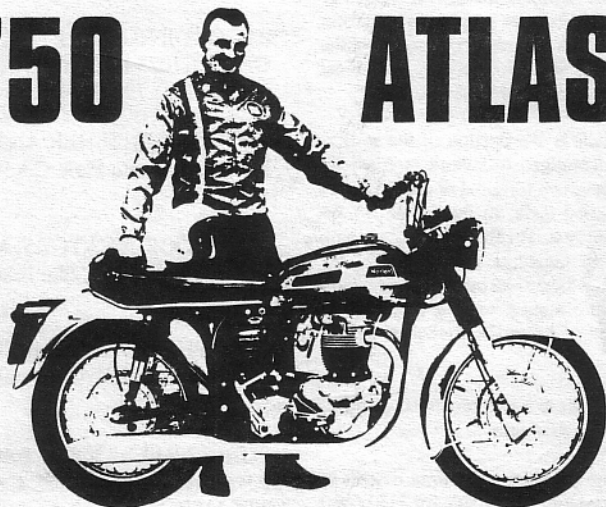

THRILLS + FUN = NORTON

A 750cc engineering masterpiece that's been rated as the outstanding motorcycle in its class by experts!

A twist of the throttle assures instant response from a meticulously prepared 60 h.p. engine of vertical twin design . . . an engine whose heritage is a direct line to 34 Isle of Man competition victories.

A touch of the controls that actuate the large, wide, full-hub front and rear brakes guarantee safe, sure stops at all speeds. The "road-holder" front fork, Girling rear shock absorbers, "leatherbed" frame and reliable and proven gearbox all add up to the most dependable road-burner on the highway.

Such extra luxuries as Dual Amal Concentric carbs, 8000 rpm tach, 120 mph speedometer, new design sports type dual-seat, 12 V. electrical system with capacitor and Avon tires are all standard equipment on your Norton 750cc OHV "Atlas".

See your Norton dealer today, and start enjoying the thrills of riding a winner!

Norton

MANUFACTURED BY NORTON-VILLIERS
The New Name in Motorcycles

Berliner Motor Corporation

Plant Road • Hasbrouck Heights • New Jersey



Norton Notice

is published by the Northern California Branch of the Norton Owners Club. Its purpose is to inform and entertain members regarding all aspects of the Norton motorcycle, including history, technical advice, and preservation of the marque.

NORTON NOTICE is a reflection of the readership, who are encouraged to submit any article, technical tip, photograph (original or otherwise) as long as it is in good taste, so that other Norton enthusiasts may enjoy it. For Branch members who cannot attend club meetings or club rides, the NORTON NOTICE affords an opportunity to share experiences and information with the membership of the Branch and to bring the Branch members closer together.

The deadline for items to be submitted for publication is the 25th of each month.

Membership in the Northern California Branch of the Norton Owners Club is available for \$15.00 per year. Membership dues are payable to the Branch Secretary/Treasurer.

Renewal dues are payable at the end of the individual's membership year, that month being designated by the last number of the individual's membership number as listed on the mailing label of the NORTON NOTICE and the membership card. For example, 745/2 denoted member 745 with dues expiring on the 1st of February.

All changes of address should go to the Branch Secretary/Treasurer, not the NOTICE editor.

The Northern California Branch of the Norton Owners Club is affiliated with both the Norton Owners Club of England and the International Norton Owners Association. Interested persons can join these two organizations per the terms described on the Branch membership application form.

CLUB OFFICERS

PRESIDENT: Lynne Miller, 639 Mangels Ave., San Francisco, CA 94127. (415) 334-2042;

VICE PRESIDENT: Marick Payton, 301 W. O'Connor, Menlo Park, CA 94025. (415) 321-5083

SECRETARY/TREASURER: Stan Beneveds, 36646 Darvon Ct., Newark, CA 94560. (415) 793-0704

RECORDING SECRETARY: Brad Green, 37028 Lassen St., Fremont, CA 94536 (415) 792-0501

NOTICE PUBLISHER: Andy McKerral, 28 Iris Lane, Menlo Park, CA 94025 (415) 322-4054

RIDE COORDINATORS: Mike Burnham, 2401A Bush Street, San Francisco, CA (415) 346-1224

PARAPHERNALIA: Leo Christiansen, 464 Alcatraz, Oakland, CA 94609 (415) 655-5083

PUBLIC RELATIONS: John Covell, 1183 Alemany, San Francisco, CA 94112 (415) 334-1183

NORTON OWNERS CLUB

IMPORTANT (Please take note of the following fine print): The object of the Northern California Branch of the Norton Owners Club is to promote, encourage and develop motorcycling activities. The Club's members are owners of Norton motorcycles and they often submit for publication in the NORTON NOTICE technical tips pertaining to motorcycles of the Norton marque. Technical tips so published have been reviewed for technical content and are believed to be both acceptable and workable, but no guarantee is made or implied that they will work correctly, nor is any liability assumed by either the Norton Owners Club or the members for any problems resulting from use of these technical tips. The club also assumes no responsibility for the acts or omissions of its members in connection with Club activities. NORTON NOTICE articles or other materials express the authors' views only and not necessarily the official policy of the Norton Owners Club or its Northern California Branch. The editor reserves the right to accept, reject or alter all editorial and advertising material submitted for publication. Advertising published does not imply endorsement of products, goods or services. Now you know.

Upcoming Events

Rides Schedule

May 5th: the Mount Hamilton Ride

June 8&9: The famous NOC/BSAOC Sierra Ride and Chili Cookoff.

July 7: a possible Napa Valley/Sonoma ride. Stay tuned for further details.

July 31-August 4: The Mother of All Rallies at Richardson's Campground in Lake Tahoe

Graphics Contributions

Cover Photo: July, 1966 CyCle World-courtesy of Tom Dable.

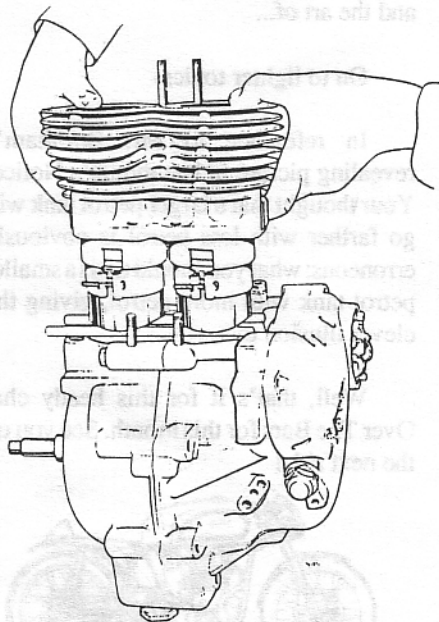

Fitting cylinder over pistons. Note piston supporting bars and ring clamps in use

Meeting Schedule

The club meets on the 2nd Thursday of each month, at 7:30 PM. (...a good time to show up for the meeting, but don't expect anything "official" to happen beyond 8:15 because of the excellent selection of beers at our meeting venues!) The location rotates between Peninsula, South Bay, East Bay and S.F.

May 9--Peninsula

The Prince of Wales Pub on 25th Ave in San Mateo offers a wide selection of beers and a private meeting room with dart boards!

June 13-- South Bay

Harry's Hoffbrau, El Camino near Castro Street, Mountain View

July 11- East Bay

Spaghetti Factory, Jack London Square, Oak-town. This is still tentative, as Brad Green is looking into a viable alternative.

ADVERTISING RATES

	<u>1/4 Pg.</u>	<u>1/2 Pg.</u>	<u>Full Pg</u>
6 Mos.	\$35	\$70	\$140
1 Yr.	\$60	\$120	\$240

Send ad copy and check to the Publisher

Over the Bars . by Lynne Miller, President

Good things don't always last forever! I'm referring to our San Francisco meeting place at the Lake Mercéd Boathouse. The ownership there has changed hands, and some major changes are underway. As the attending membership may recall, our last meeting there took place in what I would call an open hallway, and the noise level made it very difficult to conduct or understand a meeting. If we can't work out a better arrangement there, then a new location will have to be found.

This last experience at the Boathouse was unfortunate, because I feel that a major part of our Club Membership growth has been a direct result of stable meeting places. Before the Club used the Boathouse as a San Francisco meeting venue, the scheduled meetings in S.F. were lightly attended because the varied meeting places were less than desirable. At any rate, an attempt is being made to solve the problem- and if a solution is not found, then a new meeting place will be arranged.

A comment was made by one of our members at the last meeting that needs to be examined. The comment was that the Norton Club has a reputation for being aloof, stand-offish, and elitist.

Are we?

When I joined the club, it had the reputation of being a group of non-riding polishers full of techni-crap, and I soon found that to be absolutely not true.

I find now- as I found then- that that

the Norton Club is made up of an extremely diverse group of people that is, for the most part, promoting a single common interest that we are successfully promoting. In other words... we are not aloof, stand-offish, or elitist: we are a friendly, out-going group which is interested in you and your Norton. That's why our membership keeps on growing!

We, as a club, are becoming increasingly visible to the Motorcycling Public: with our involvement in activities such as the Easter Morning Ride, the International Norton Owner's Club Rally, and many other special events, it is vital that we maintain harmony within our own ranks. My event is not any more or less important than yours... therefore, I will work with you, and not against you. Zen, and the art of...

On to lighter topics-

In reference to Mr. Burnham's revealing picture in last month's Notice: Your thought that a larger petrol tank will go farther with less petrol is obviously erroneous: what you should try is a smaller petrol tank with more petrol, giving the clever illusion that...

Well, that's it for this heady chat Over The Bars for this month. See you on the next ride!

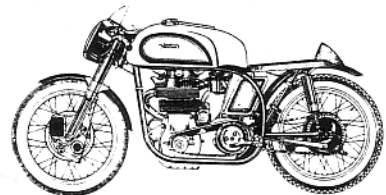

Minutes of April Meeting

The NOC April '91 meeting at the Lake Merced Boathouse in San Francisco was called to order at 8:00PM by President Lynne Miller. Attendance was 26 members.

Lynne's commentary on the Easter Ride was that there were 400+ bikes present; it was a great ride and all went well. Various groups of pictures from the ride were passed around for all members in attendance to see.

The International Norton Owner's Club Rally Committee in attendance requested additional help with the rally: i.e.: registration and ticket sales.

Patrick McDowell, safety officer for the Rally, commented that he will be contacting hospitals and health facilities in the Camp Richardson area to get information about the available services in that area, and to publicize these emergency resources at the Rally.

The April 14th Club Ride scheduled to depart from Skylonda at 10 AM will be heading for Stagecoach Road. This ride is being referred to as "MIKE'S Ride", due to his particular fetish for this route. (Ed's Note: See the Ride Report later on in this issue... even "self-gratification" would be unfulfilling on a day like what we had to deal with on that ride... everybody who showed up was too sick, grumpy, or full after breakfast for a real tour.)

A decision has been made regarding the raffle of the Club Bike. Raffle bike ticket holders *need not be present* to win.

A new San Francisco meeting venue is needed- the Boathouse is no longer suited to the needs of the Club. We'll discuss this in depth at the May meeting in

San Mateo.

NOC Publisher, Andy McKerral, reaffirmed that the deadline for all Norton Notice Material is the 21st of each month! (Ed.s' Note: Go ahead, punk-make my day...)

NOC Member Jerry Kaplan of Davis, Ca., will be hauling an 18' bobtail to the Rally. For more information, contact Jerry at (916) 756-8894.

At this point, Maya Lai voiced her **personal** displeasure with the Raffle Bike- i.e.: parts, hardware, and overall Club effort.

The meeting was then promptly adjourned at 8:20 PM.

Brad Green, Scribe

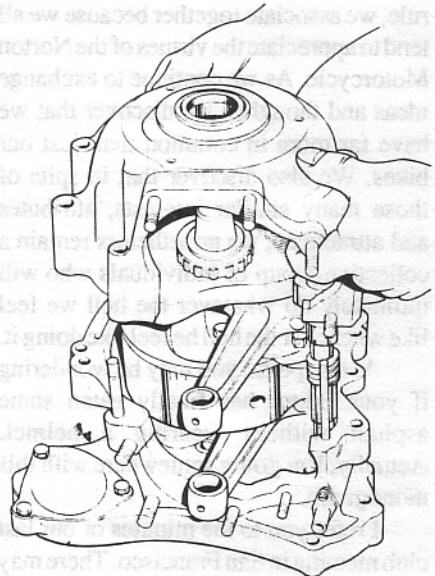

... Side Trips

by Andy McKerral

It's strange that I should find myself discussing these issues in our club; to be sure, there are those of us who travel socially in groups, who have one or two close friends within the club, or still others who choose to be loners- this phenomenon isn't anything new to the human race, let alone a motorcycle club. Human beings in general tend to do whatever the hell they feel like doing, whenever the hell they feel like doing it. We've been like this since we first learned to use a blade of grass to pick ants out of anthills for food.

One of the things about human beings, however, is that while they exhibit independence, they still like to associate with others of their kind. Our own little microcosm of this anthropologic phenomenon is called the Northern California Norton Owner's Club. As a rule, we associate together because we all tend to appreciate the virtues of the Norton Motorcycle. As we continue to exchange ideas and thoughts, we discover that we have far more in common than just our bikes. We also discover that in spite of those many similar interests, attributes and attractions, we nonetheless remain a collective group of individuals who will ultimately do whatever the hell we feel like whenever the hell we feel like doing it.

At this point, you may be wondering if your Editor has finally eaten some asphalt without wearing a helmet. Actually, I'm going somewhere with this monograph.

I refer you to the minutes of our last club meeting in San Francisco. There may not be any point in belaboring the issue,

but the simple truth is that without a thorough understanding of what happened, it may be mistaken by our rural, out-of-state, and international Notice subscribers that credit was due and not given to those who contributed to the efforts on our Club Raffle Bike.

I assure everyone that this simply is not the case. As many back issues of this newsletter will recall (for over a year now, in fact), I continuously solicited help, assistance, parts, technical guidance, painting- and, yes, an occasional pat on the back for and in behalf of the Club Bike. I dutifully reported on the machine's progress when it was appropriate to do so, and continued to solicit all that I needed to fulfill the Club's stated objectives for the bike: Produce a marketable, presentable, working motorcycle for the purpose of raffling it off as a fund raiser. The objective was NOT to create a concours machine destined as a conversation piece for display in the boardroom of some millionaire's office in the financial district of downtown Tokyo, but a machine that the fortunate owner of the winning ticket could ride and enjoy.

Yet, one individual decided that this machine was not up to their standards, and then proceeded to engage in a very extensive carping session before a large group of our club in a public meeting house.

This individual made many subjective accusations: not only directed at the Club Bike and the efforts that went into it, but some rather vicious statements were also made concerning the local Club Members as well. Additionally, this individual made some very heady comparisons between our Club and the BSA Owner's Club- more specifically, our Club Bike to their

Club Bike.

While one must consider the source, the fact remains that much was done by this individual to spoil our meeting by such a diatribe. It was not unlike being on a club ride and having to drive by a nasty motorcycle accident, and then afterwards having to hose your boots off from the splatter.

Though I am personally not a member of the BSA Owner's Club, I do have several friends who are... and to them I must apologise for this individual's lack of vision. We never have entertained the idea that one organization was better than the other; in fact, we have enjoyed our association on those occasions where our paths have crossed- and hope that they'll continue.

It is also interesting to note that not a single erg of this individual's energy was donated to this bike; nor was this individual responsible for donating even so much as a shakeproof washer... until *after the bike was publicly exhibited*. Thereafter, the lot was cast for this individual to use it as an excuse to chastise the Club for whatever axe they have to grind with the rest of us.

While it would be far easier to ignore this incident, I personally cannot. A very few generous people donated one hell of a lot of time, muscle power, parts and money to bring that machine back from it's original deplorable state. The bike is no longer in my garage- and, as such, it is now out of my responsibility loop- but I still have the responsibility, as former project head of the endeavor, to uphold and applaud the efforts of those who *did something* to enhance the Club (instead of put it down), enjoy each other's fellowship (without beguiling others), share our interests in the virtues of Norton

motorcycles (without placing comparative values on other Marques)- and STILL do whatever the hell we felt like doing, whenever the hell we felt like doing it.

Now that I've vented my spleen, there's one more observation I'd like to make.

There's *gotta* be someplace more conducive to holding a club meeting in San Francisco besides The Boathouse-like maybe an ordnance testing range. A little bar called "Yancy's" on 12th and Irving comes to mind... I wonder if the USF crowd has taken that over, too? It used to be a great place to get slowly crooked as you muddled your way through the morning Herb Caen offering, and mentally finish writing that goddamn book that you finished only thirty-two chapters on. Perhaps there are other suggestions.

See you at the Prince of Wales real soon. Leave your darts at home, Phil- I noticed last time that Lynne likes to stand dangerously close to the boards... and volunteers for a replacement President without combat pay would be few and far between.

Last Minute Tidbits:

The Club Raffle Bike was displayed for exhibition at the Tulare Meet on the weekend of April 26th-27th, where it was anticipated that more than just a couple of raffle tickets were sold. From there, the bike will be displayed at Mean Marshall's in Berkely for a period of time.

Meanwhile, your Editor received an anonymous message on his AnswerPhone from someone with a distinct Scottish brogue accent that Thackery Washer, NOS, will be "revealing himself" in the next issue of the Norton Notice. Will this pub's pressman be required to report this incident to the authorities? Stay tuned!

International Norton Owners Association

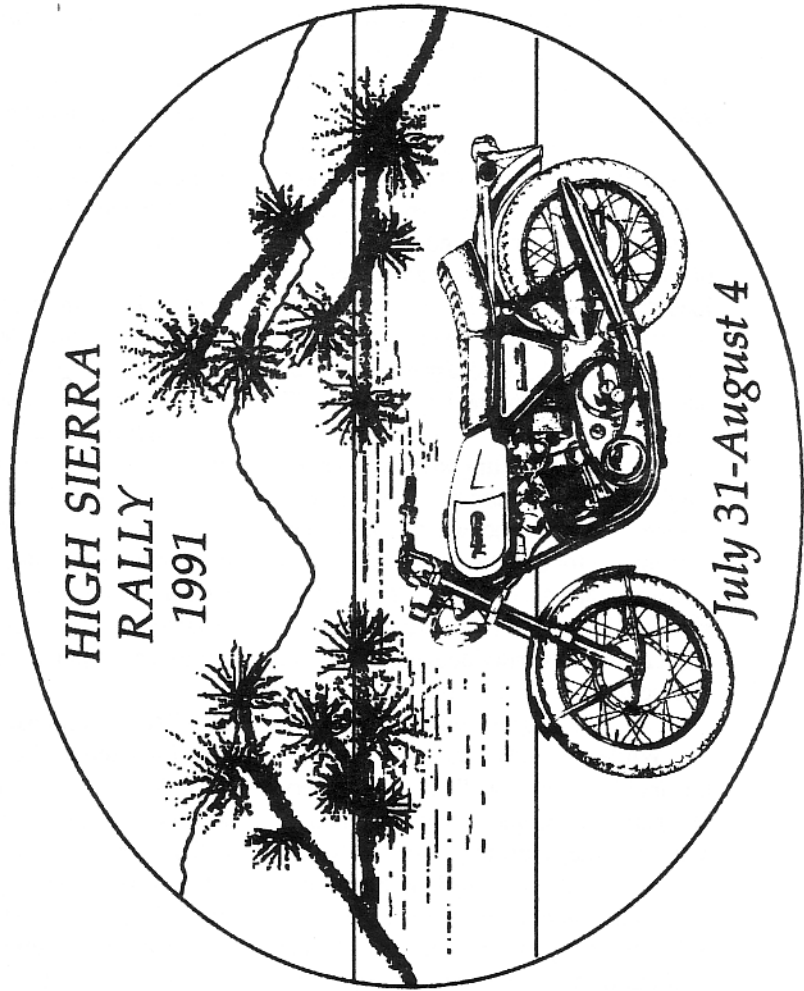

July 31-August 4

Richardson's Resort, South Lake Tahoe, CA

Rally fees: Adults \$40.00 (\$35 before 7/1/91)
Children 5-16 yrs \$10, under 5 free

Note: Full RV hookups and family cabins are available separately. Contact Richardson's Resort at 800-544-1801 for reservations (required).

Fees include the following:

- Four nights camping
- Daily rides and tours
- Complimentary raffle ticket
- Awards and door prizes
- Friday barbecue with live music
- Saturday banquet

Special events and features:

- 1971 Commando Roadster raffle
- Five passes poker run with cash prizes
- Overnighter to Yosemite Park
- Breakfast served every day
- Free Casino shuttle

To preregister, complete the form below and mail to:
Harry Bunting, 1165 Crandano Court, Sunnyvale, CA 94987

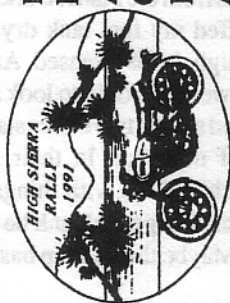

Mail this form to: Harry Bunting, 1165 Crandano Court, Sunnyvale CA 94987

Name: _____

Address: _____

City: _____

Zip: _____

INOA #: _____ Number in party (adults) _____ (children) _____

Amount enclosed: _____ ALL FUNDS IN US DOLLARS

April Ride Report

by Mike Burnham, Rides Marshall

I guess that I owe everyone an apology for not getting the word out in time for the April Ride. However, for those of you who feel that they missed out, not to worry...

The ride was supposed to start from Alice's at Skylonda at ten o'clock (ON the fourteenth, of course). The overcast, which was everywhere, touched down on the mountain, making everyone cold and wet - thus dampening their enthusiasm. Ten people did show up, however, and I thank you for that. It seems that between the lateness of the March Ride, and the earliness of the April Ride, planning and forethought had fallen by the wayside. If a ride had to be cancelled, April's couldn't have been a better choice.

SO, since there was no ride to report on, I'd like to discuss THAT photograph in last month's issue. If you are to try and think of a title, you should at least know the truth about it - and, yes, that's me putting fuel in my tank from a Bud Lite bottle (unleaded). Well, it's like this: my motorcycle and I were abducted by an outlaw band of time-travelling drug-addicted aliens from the Planet Dork. After they had sniffed my fuel tank dry in an effort to get high, I was released. Anyone doubting my word has only to look at that photograph and see the two Dorks standing either side of my bike. In their petro-stupor, they chided me with things like: "How can such a large fuel tank be out of gas?" and, "Maybe the fuel tap has black goop in it".

I would also like to point out that there is no truth to the rumor that I had my BAP fuel reserve tap turned in the wrong

direction, and therefore could not access my reserve fuel. Absolutely no truth whatsoever. Honest. (Ed.'s. Note: This incident was recently reported to the Air Force's Project Bluebook people in Colorado Springs, and they are continuing to look into the matter - in the meanwhile, check out future editions of the Enquirer for further updates.)

As far as the upcoming rides are concerned, the May Mount Hamilton Ride might have already taken place by the time you receive your Norton Notice as it is an early one (May 5th). If that is the case, we had a great time! See you at the Chili Cookoff!

The Covell Column *cont'd from page 13*

them without an assurance that his answers would not be used against him in any later criminal proceedings. This assurance was not forthcoming. In the event, he obliged the investigators with factual information about Norton's history, but refused to answer questions under oath that might relate to criminal offenses. His refusal may get him jailed for contempt of court unless he can persuade a judge that he has a reasonable excuse for not cooperating. (The right against self-incrimination, guaranteed in the U.S under the Fifth Amendment to the Federal Constitution, extends in Britain to criminal suspects under a statute that the DTI maintains does not apply to inspectors appointed pursuant to the Companies Act. Mr. LeRoux seems willing to make his a test case.)

At the end of March, trading in Norton shares was suspended because of a delay in the group's publishing of its financial results for the six months ending October, 1990; they should have been released at the end of February. Norton is negotiating the appointment of a new CEO and also hunting for new stockbrokers, as well as a new merchant banker. The DTI investigation continues.

Tech Tip

by I. Pushtit Holme

Personally, I find that the original Amal Concentric carbs used on the Commando are perfectly suited for the job. So, when they wear out, I would rather stick with Amals than go for a more modern alternative.

Amal 900 series concentric carbs are still being manufactured, but the price can be high. Fortunately, there is now a way to get your old Amals "reborn" and made better than new. A fellow named Mike Gaylord up in Washington State offers a re-sleeving service which is highly precise, and gives a better, longer-lasting fit than new Amal carbs. Several suppliers around the Bay Area act as representatives for Mr. Gaylord. These include Raber's European Cycle Works in San Jose, as well as Fair Spares America, also in San Jose. You can call these distributors for the pertinent details; however, you'll also find this re-sleeving service very reasonable. Check it out.

Also- a bit of news:

Should you discover a May, 1991 issue of **Bike Journal**, you'll find an extensive article written by Art Sirota with photographs by Chris Nichols. This Dynamic Duo has teamed up once again to present an article chronicling the restoration of Art's 1948 Norton International.

Bike Journal is published in Connecticut and is available at many local newsstands. If you want to have a copy sent to you, write **Bike Journal** Subscription Service- PO Box 391- Mt. Morris, IL 61054.

(Ed.s' note: if you spot someone riding a 500-T delivering magazines instead of the Chronicle at 6:00 AM, it's an ArtForm.)

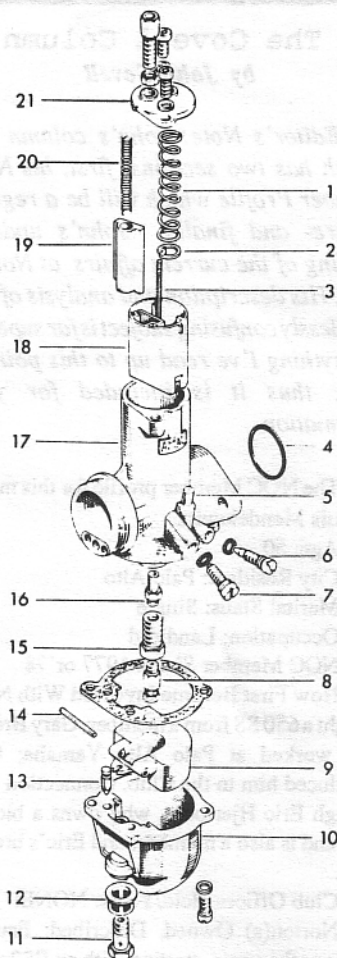

COMPONENT PARTS OF

THE AMAL CONCENTRIC CARBURETTOR

- | | |
|---------------------------|----------------------------|
| 1 Throttle return spring | 7 Throttle stop screw |
| 2 Needle clip | 8 Main jet |
| 3 Needle | 9 Float |
| 4 'O' ring | 10 Float chamber |
| 5 Tickler | 11 Banjo union bolt |
| 6 Pilot jet screw | 12 Filter |
| 13 Float needle | 19 Air slide (choke) |
| 14 Float hinge | 20 Air slide return spring |
| 15 Jet holder | 21 Mixing chamber top |
| 16 Needle jet | |
| 17 Mixing chamber body | |
| 18 Throttle valve (slide) | |

The Covell Column

by *John Covell*

Editor's Note: John's column this month has two sections: first, his NOC Member Profile which will be a regular feature- and finally, John's updated briefing of the current affairs at Norton PLC. His description and analysis of this hopelessly confusing subject is far superior to anything I've read up to this point in time: thus it is included for your information.

The NOC Member profile for this month is Louis Mendelowitz.

Age: 50

City Resident: Palo Alto

Marital Status: Single

Occupation: Landlord

NOC Member Since: 1977 or '78

How First Became Involved With NOC:

Bought a 650 SS from a member, Gary Broder, who worked at Palo Alto Yamaha; Gary introduced him to the Club. Connection also through Eric Hjertberg, who owns a bicycle shop and is also a member; and Eric's brother John.

Club Offices Held/Years: NONE!

Norton(s) Owned, Described: Four or five over the years, starting with an ES2 years ago. Presently has a '70 Commando Fastback.

Other Makes of Motorcycle: Four BMWs, a Maco, two Hondas, and a Yamaha.

"What first interested you in a Norton?":

Got ther ES2 when he wanted something more couth than a Velocette. Just liked the idea of the ES2.

Other Hobbies/Interests of Note:

Bicycling; mostly mountain bikes now, but also some road biking.

Favorite Motorcycling Road or Ride: No

current favorites. "The new road is always nice, the old roads are all so full of traffic that they're just not as much fun as I remember

there being in the past." Fond of the roads off Skyline that he learned to ride on—they're all old friends.

"If you could redesign the Norton, what one thing would you most want to change? How and why?": "The rotary is a good thing, as the parallel twin in it's 750 and 850 states is "...a little overgrown."

Favorite or Most Embarrassing Episode on a Norton: "I've seldom been let down by the Norton; but the few times I have been were fairly spectacular... not anything I'd like to dwell on. Never had an accident, only mechanical failures."

Thank You!

Part Two: NORTON GROUP PLC

A great deal has happened in Norton Group's corporate affairs over the last six months—much of it disturbing not only to shareholders, but also to Norton motorcycle enthusiasts. I have reviewed the related British press and tried to digest developments for NOC members. The following is, believe it or not, a simplified account. Bear in mind that most of the events described occurred in the U.K., and that English law applies. All monetary figures are stated in pounds sterling.

A couple of years back, Norton Group bought a New Jersey company, Pro-Fit, which makes pipe fittings. The intent of this move was to diversify so that Pro-Fit's earnings could help subsidize the loss-making engine and motorcycle sides of the Company. Pro-Fit's owner, Yehuda Mendelson, sold his operation in exchange for cash plus an 8.5% share of Norton Group, making him the largest individual shareholder. Last November, after certain property divestments failed to yield expected growth capital, Norton called a special shareholders' meeting to approve a "rights offer" of new shares, the sale of which was intended to raise 6.5 million pounds sterling to fund Norton's planned purchase of a Germain fasteners manufacturer, FUS, for a total of 8.2 million pounds (7.6 million plus the assumption

of some debt). Then the fun began.

FUS was founded some 22 years ago by James Tildesley, recently Norton's non-executive Chairman. Mr. Mendelson objected strongly to the proposed acquisition. Aside from watching the value of his Norton shares decline steeply over the proceeding two years, his chief complaint was that in 1989 Mr. Tildesley had sold FUS to Roybridge, a private trust controlled by his family, for 3 million; and now, a year later on, Norton proposed to buy it from them 5.8 million cash...plus, apparently, forgiveness of a 1.8 million "soft loan" by Norton to Roybridge to assist an earlier purchase. (A "soft loan" is one not disclosed to the lender's shareholders. Norton was subsequently persuaded by the Stock Exchange that this loan should have been announced to the shareholders.) Philippe LeRoux, Norton's CEO, said that the price was fair, and another director noted that FUS had been independently appraised, but Mr. Mendelson threatened litigation and the Stock Exchange ordered an adjournment of the special meeting so that the shareholders could be provided additional information. The rights issue was ultimately approved by 80% of the shareholders... but only by the use of proxies submitted prior to the required additional disclosures.

The authorized new shares did not sell well, and in mid-December the underwriting stockbrokers still had almost 89% of the offered shares on their hands. In January 1991, the Department of Trade and Industry (DTI) appointed a barrister and an auditor to investigate Norton's affairs under the fraud provisions of the Companies Act (more on this shortly). Also in early January, the brokers announced that they had failed to honor their full underwriting commitments on their rights issue, and needed an extension of time to raise the money because certain sub-underwriters (including Mr. Tildesley) had let them down. Raising the additional money was made difficult when, consequent to announcement of the DTI investigation, the price of the shares

fell on the Stock Exchange to a level lower than that of the rights offer. Norton asked the Stock Exchange to suspend its shares until the brokers paid over the rest of the money promised to Norton's bankers. The brokers subsequently did receive most of the funds, paid them over, and the bankers completed the approved acquisition of FUS. (Norton group's bankers have since resigned.) Mr. Tildesley's share purchases raised his Norton holdings to 11%, and another sub-underwriter now held 14%, but the brokers continued to hold 19% of Norton's equity themselves as security against a defaulting sub-underwriter. (The stockbrokers and other advisors received 1 million in fees.) The brokers' regulatory body, the Securities Association, subsequently ordered the firm to stop trading for having insufficient capital, and in early February two of the firm's senior executives were arrested on unrelated fraud charges. The firm later went into receivership.

Under a statutory DTI investigation, documents requested must be produced and witnesses can be compelled to attend without the right to remain silent, even though they may incur criminal liability. The investigators said their inquiries would go back three years; whether the rights issue is involved remains to be seen. Mr. LeRoux said he was shocked and did not know the reasons for the investigation. Norton lost almost a third of its current value when the DTI investigation was announced, its shares dropping to a new low that was one tenth of the high a year before. Three days later, Mr. LeRoux resigned following his failure to pay 195,000 pounds (his cheque bounced) to the agent that had purchased Norton shares on his behalf. Norton's bankers said that the resignation was unrelated to the DTI investigation. Mr. Tildesley was to take over as CEO, while Mr. LeRoux retained a consultive role. But even before Mr. LeRoux's resignation, Norton's board had cut the motorcycle workforce from 105 to 80.

Meanwhile, Philippe LeRoux told the DTI investigators that he would not assist

Classified Advertisements

For Sale: 1971 Commando Roadster: new top end, clutch, tires, seat. Licensed. It runs well. \$1800. Tom Spoichich, at (415)537-4559 (Castro Valley)

For Sale: Norton SHV & OHV Singles oil tank cap (A/291). Fits Model 18, 16H, ES2, 500T, etc. 1946-1955. Just Re-Chromed. \$50. Art Sirota at (415)327-3167.

For Sale: 1973 Commando Interstate. Very clean, runs perfectly, factory updates, receipts. 16K miles, 2nd owner. \$3400, or trade for BMW R100/R90, or best offer. Mart Johnson at (707) 226-6982

For Sale: Disc brake conversion parts- 3 sliders, 2 brackets, 2 calipers, axle, hub, 1 rotor, master cylinder, brake lines. For earlier Commandos. Eric Reiner at (209) 522-4498

For Sale: '71 & '72 Norts 750 (\$1500 & \$1300), '72 Dunstall 750 (\$2600), '71 Bonnie (\$1300), '68 T100C w/'72 motor (\$1300), '66 T100R dirt setup (\$750), '78 Yam TT500 dirt (\$500), '78 KTM250 dirt (\$400), tankbags, fairings, some books, tools and parts. All are titled, most are in project stage. Help a Club Member reclaim his garage. Call Lou Caputo at (415) 527-6803. After May 11th, sale is scheduled for general public.

For Sale: '76 850 Mark 3. Clean, runs good. Single Mikuni setup Black. \$1850. Call Paul Barmon (415) 695-7854

For Sale: '74 850 Interstate. Very good condition,, ridden to Canadian Rally in '89. \$2600. Also, 850 ring compressors, like-new, \$20. Contact Marick (415) 321-5083

**Yes, there is still a Club Tools
loan-out program!
Contact Harry Bunting for
details**

CLUB GOODIES

*(formerly called "Paraphenelia",
but hey, we're upgrading our image!)*

1. T-Shirt, New Design. Silver on black- also, Red on Silver
Long Sleeve: XL-5; L-3; M-5; S-2 **\$18.00**
Short Sleeve: XL-4; L-3; M-5; S-4 **\$15.00**
2. T-Shirt "My Success is due to my Unapproachable Norton"
Gold on Black, very shrinkable XL-1 **special \$8.00**
3. Norton Hat: Black on silver. One size adjustable. **SOLD OUT \$4.00**
4. New Ca. NOC Pin. Red, white and blue on gold; 7/8" square **\$4.00**
5. Old NOC Classic "N" pin. Red on Silver **\$2.75**
6. Commando Service Notes, 45 pages, printed in England by NOC **\$5.00**
7. Decals- Classic "N": small- sold out- .50; large (4"x4") **\$6.75**
8. Cloth Patches- Classic "N": small- sold out- \$1.50; large (4"x4") **\$2.50**

All orders sent UPS or Postal and charged accordingly.
Call (415)655-5083 to place your order.

The above list of Club Paraphenelia is all available at this time. In past years, the assortment was more varied, but it didn't sell well, or there was inadequate profit margin to justify continuation of the individual product. This Club activity is not a big revenue generator- but, like any business, we try to carry high quality, high demand items bought at low cost and sold at reasonable market prices. This is a Club Service for it's members, as well as a revenue generator for Club Activities. So, now you know- but there again, you already did...but you may not have let anyone else know that you knew! The remaining question is: *what can you do to make the Club better?*

Leo Christiansen

Norton

Owners Club

**NORTON
A.J.S.**

**TRIUMPH
B.S.A**

VELOCETTE

**BRITISH
MOTORCYCLE
SPECIALISTS**

**Repair • Rebuilding • Tuning
Bikes & Parts Bought and Sold**

**Fred Twigg
Sebastopol, CA (707) 823-9165**

**25 YEARS EXPERIENCE
VERY COMPETITIVE RATES
YOUR NORTH BAY ALTERNATIVE!**

GENUINE
Norton

PARTS
means

**FAIR SPARES AMERICA.
INC.**

Norton Specialists

PHIL RADFORD

(408) 292-6563

PO Box 8224, San Jose, CA. 95155

Send First Class for Current Lists

Full Range of Stainless Items

NORVIL Production Parts

24 Hour AnswerPhone Service

Mail Order, UPS, COD, MC, Visa

You'll find more than
motorcycle parts &
service at Raber's!

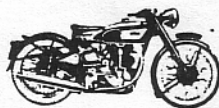

At Raber's you'll find an honest, experienced friend with cycle expertise. Ask for Bob or Bill and solve your motorcycle problems today.

Raber's supplies parts for

**Norton TRIUMPH DUCATI
BSA MOTO GUZZI**

Raber's

European Cycle Works, Inc.
1615 Alameda Rd.,
San Jose, CA 95125

(408) 998-4495
Tu-Fri 9-6
Sat 8-5

**Norton TRIUMPH
DUCATI CAGIVA
MOTO GUZZI
MUNROE MOTORS, INC.**

MOTORCYCLE
SALES - SERVICE - PARTS

SINCE 1958

Munroe has three mechanics who are familiar with Nortons and have been for a number of years. We can replace exhaust ports with the head on the bike, and don't know of anyone else who can. The job looks like original factory. Call for a quote on shop prices. We also have a good Norton parts supply.

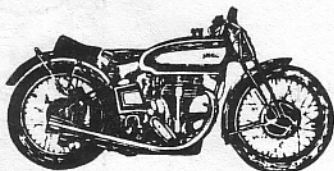

412 VALENCIA STREET
SAN FRANCISCO 94103
PHONE (415) 626-3496

Norton

**ELECTRIC
STARTERS**

**Made to work
as God Intended!**

Starter Parts considered for purchase

Contact

BURTON KRANZEL

(415) 261-8252