



Norton Notice



The Newsletter of The Northern California Branch

VOLUME 3 ISSUE 11

DECEMBER 1980

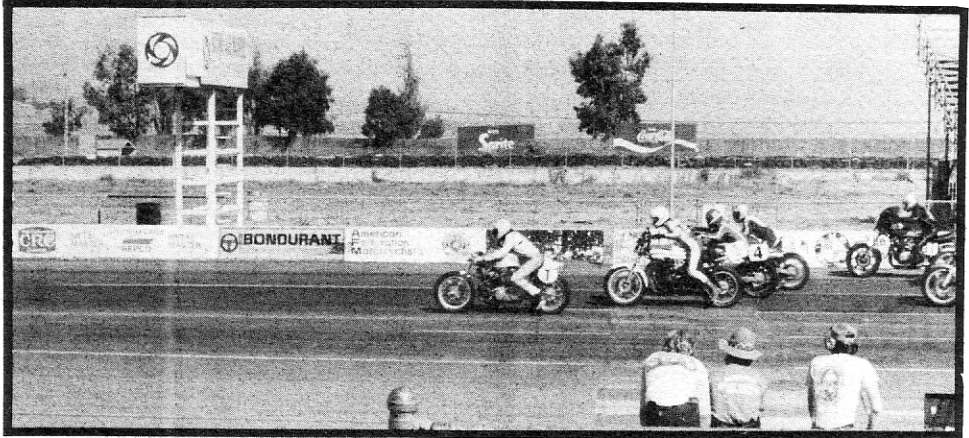

Mark Ingalls pulls a hole shot on the rest of the field in 1980's AFM Endurance Race. Although sidelined with electrical problems, fellow Norton owner Gary Broeder won the race. The story of last year's win is inside.





THE EXHAUST NOTE



Published monthly by the Northern California Branch, Norton Owners Club

BRANCH OFFICERS

PRESIDENT

Steve Coburn
P.O. Box 236
La Honda, CA 94020
(415)747-0326 Home
(415)497-6601 Work

SECRETARY/TREASURER

Tom Horton
250 Curtner Ave. #26
Palo Alto, Ca. 94306
(415) 493-2157

NORTON NOTICE STAFF

- Michael Heth
- Meda Rago
- Bob Marshall
- Gene Austin

Material of any sort for the Club newsletter is best handled through the mail. Please address correspondence to:

NORTON NOTICE
c/o Michael Heth
87 Ord St., Apt. 3
San Francisco, CA 94114

BRANCH MEETINGS

Generally held the second Thursday of each month at a location announced in the NOTICE. Every effort will be made to convene meetings between 7:30 and 8:00 in order to conduct the business at hand. This will allow members who have come a long way to get home at a decent hour.

BRANCH RIDES

Rides are generally held the Sunday following a meeting at a location announced in the NOTICE. Rides depart promptly (usually 10:00 am). Conscientious members will be fully gassed; no stops made for about an hour. In the event of rain the ride is postponed 1 week. Occasionally, the ride day/days vary. Check the NOTICE Calendar each month to be sure.

Hopefully, this NORTON NOTICE finds all the members undaunted by the colder weather and precipitation. Some of the nicest days of the year occur during the coming months, and it's just a matter of getting up and going in the cold Sunday morning to allow you a nice day of riding. One thing you'll notice is less traffic as Sunday Drivers knock it off a bit this time of year. So, let's have a big turnout for the ride coming up this month. Our branch of the NOC seems to have developed a great deal of momentum this last year as more and more people are taking part in club activities. We now have about 7 people taking an active part in getting your newsletter to you each month. This is a marked difference from last year, and it can only get better because of it. The newsletter is just that - a (hopefully) timely accounting of the activities of this NOC branch and its members. The more people interact with the other members either through the meetings, rides, or newsletter, the more fun Norton ownership will be. (This is just another of those thinly disguised exhortations for YOU to send in that little bit of Norton-related info.) Aren't you tired of them yet? C'mon there's only one sure way to stop them. Need a pencil? We'll mail you one. (Although 3 members burned my soapboxes, you can see I found some more.)

There are quite a few ways the Club can be more fun in the next year. One way is for different people to plan the rides. Everyone has a favorite ride somewhere. If only 12 out of the 150 or so No. Calif. members step up to plan one ride each, we'll all have 12 really fun rides to places Norton Owners find interesting. So, step up. It's only a little work and a lot of enjoyment showing your fellow NOCers the way around. Another way is the tech session. This year Jan Barton did one on his Manx Motor, and it was enjoyed by all. Some of you out there could do one on some aspect of the bike and really help your fellow members out. Think about it and c'mon. It's all in the name of NORTON. Well, this is enough of this stuff. Have some happy holidays.

All power to the Pun,

Chuff



BRANCH EVENTS

<u>DATE</u>	<u>TIME</u>	<u>PLACE</u>	<u>EVENT</u>
12/12	7:30	Edinburgh Castle	Christmas Party
12/14	10:00	Sausalito Hotel Lot	Branch Ride
1/8	7:30	Edinburgh Castle	Branch Meeting Annual Election
1/11	10:00	???????	Branch Ride

At the Christmas Party there'll be a clipboard and list so members can sign up to plan a branch ride. This way the club will go on more varied runs and more members can participate. Sign up. The activities can only get to be more fun if you help out too.

As you can see the next 2 meetings are scheduled for the Edinburgh Castle. The December meeting is on Friday- our annual CHRISTMAS PARTY. Last years was a big success, but Maya Peterson (the organizer) needs help from all the members. Try to bring something to share with your fellow Norton Owners. Rumor has it there'll be a Turkey present and we're not talking about one of the members either. The January meeting will be our annual club election. The Edinburgh Castle allows us a separate room for our funtions and is therefore the better choice for these 2 important meetings. We should all try hard to bring up any important issues that the club needs to decide (such as future meeting sites) because our January meeting will be one of the larger turnouts and we can decide things, get them behind us and get on with the really important things in life- Riding Norton Motorcycles and enjoying our friend's company.

This year's December ride will be very similar in route to last years extremely popular ride but with a few slight changes. We'll meet again at the Sausalito Hotel parking lot and depart promptly at 10:15 with no gas stops until Inverness about 45 miles away. We take the Tam Junction cutoff and wind down to Muir Beach but then we'll cut inland towards Muir Woods. Past Muir Woods and back up the hill, then left onto Panoramic Road. That will take us farther up the mountain and there'll be some spectacular views off to the left of the entire bay area. The view stretches from Richmond across to Pacifica and if you stop to savor it

no one will blame you. Panoramic climbs up a little farther and then begins to descend through the woods and opens up over Stinson Beach with a new outlook on that little community and it's beautiful beach. At Hwy. 1 we turn right and the rest of the route is the regular run up the coast to Inverness. Vladimir's Czechoslovakian Restaurant has reserved their back dining room for us. The food is ethnic, the drinks are excellent and Vladimir is a real character so expect a good time here. For those with a more pedestrian palate the Inverness Cafe is right across the street although it isn't much cheaper. Vladimir's lunches are \$4.50. A Chevron is across the street for gas and has been open every time I've been there. As the restaurant doesn't open until 12:00 anyway I'd like to advocate a type of riding I call "Torqueing"- just throw it in 2nd or 3rd and leave it. This will allow you to enjoy the nice scenes while taking advantage of "Los Monsterouso De Grande" powerband of your machine. Folks who want to hot dog it should probably meet at Tam Junction early in the morning so they can blow off some Japs on the regular Inverness ride/race. On the last ride a members bike went down on a sharp slow corner and nothing puts a damper on your spirits as seeing a beautiful Norton get scraped up. As the area we'll go through is sometimes damp caution is advised.

After lunch the rides seem to break up and there are a number of ways to go. First you could ride on out to Bolinas and check that little place out. Some of the last vestiges of the Haight in '67 make this place their home. The ride on up to Marshall and then right over to Novato is especially nice. There's also the ride back down Hwy. 1 to S.F. The climb back up the coast after passing Muir Beach affords a different view of the S.F. skyline.

This time of the year it's usually overcast early every morning and it clears around 10:30-11:00. So unless it's outright raining the ride will be on. If it does rain of course be sure to come the next week.





The Prez's Page

This will be my last such message to you as President of the Northern California Branch, for I plan to step down prior to our scheduled election of officers at the January meeting. There are many reasons, needless to say, for my decision not to seek re-election, but basically I feel that the time is right for some new leadership at the helm. As most of you are all too well aware, the Branch has sailed through some rough seas this year. In the hope that I might help to calm whatever remains of the storm, I would like to use this opportunity to express a few of my personal feelings about where the Branch has been, where I think it is now, and where I hope it is going.

My involvement as an officer in our Club began three years ago at a meeting at the Edinburgh Castle when Gene Austin retired as Secretary of the then San Francisco Branch. None of the dozen or so members present at the meeting that night seemed interested in assuming the post, so I got the notion in my head to volunteer. At the same meeting Bob Getts stepped down as President of the Branch, generating another position no one was particularly eager to fill. But Bob Marshall accepted a nomination, and we were both duly elected. We wondered what we'd gotten ourselves into! Although both relatively new members at the time, we had enjoyed the meetings, rides and other activities during the year and realized that it was a good club worthy of a bright future. For my own part, I had no idea whether I could do as good a job as Gene had done, but I made a promise to the members at the meeting, and especially to myself, that I would give it my best effort.

At the time the Branch was seven years old and had about forty members. The complaints most commonly heard concerned the relative lack of participation at meetings and rides. The First Annual Norton Beer Bust was recent history, and based on the large turnout that day we knew there were plenty of non-NOCer Norton enthusiasts around. The major problem facing the Branch, as we saw it, was how to spread the word about the Club. We attempted to get a better feeling for what the members wanted by circulating a questionnaire asking for input on a wide variety of issues. We also decided to expand Gene's newsletter to include Branch ride photos, technical tips, and other information of general interest to Norton owners. The first NORTON NOTICE, a photo-copied, three-page masterpiece, went out to the members in April, 1978.

I knew it could only get better, and indeed it did, expanding quickly to six pages, and featuring, among other things, some of Bob's outstanding photos of the Second Annual Beer Bust, a proposed logo design for the proposed Northern California Norton Association, and reports of controversial meetings at which a few ideas about a possible joint affiliation with the NOC and the USNOA were kicked around.

By August of 1978 the Northern California Branch of the NOC had emerged, offering full NOC membership as before, and the much less expensive "associate" membership for those who did not necessarily want the ROADHOLDER, but still wanted to belong to a strong local club of Norton enthusiasts and receive the increasingly popular NORTON NOTICE.

The response to the associate membership idea was phenomenal, and in the next year we grew to three times the membership we had in early 1978. Unfortunately, Bob and I had a falling out at the end of that first summer, and he resigned as President of the Branch and as co-Editor of the NORTON NOTICE. Not wanting to see it die in its infancy, I decided to continue publishing the newsletter on my own. In addition to my time-consuming duties as Secretary/Treasurer, I solicited articles, artwork, technical tips and ads, did a lot of the writing and all of the editing and typing, took the layouts to the printers, stuffed, addressed, stamped and mailed all the envelopes, and then while heaving a big sigh of relief thought about the next issue! It sounds like a big job, and it is. The people who donate their time each month to put out the NOTICE deserve our appreciation. If I sound at all proud about the job I did in '78 and '79, I guess it's because I am. I worked hard at it, did the best I could, and honestly believe that our Branch newsletter became one of the best around. I'm pleased to say it still is.

By late 1979 the work load had begun to take its toll. Carollyn Scott, who had very kindly helped me with the envelope stuffing, etc. on numerous occasions, volunteered to serve as Secretary/Treasurer and thus relieved me of a major burden. To her I will be forever grateful. In response to my pleas for a new Editor, a triumvirate of Dick Swanson, Michael Heth and Brian Halton volunteered; at the end of 1979 I passed the reins on to their able hands. At the time the Branch was almost 200 strong, and Bob Bausch was stepping down as President. Although realizing that the planning and organization of the 1980 USNOA Rally would keep me very busy, I still wanted to continue to work for the Club in some capacity. I was encouraged by many of you to run for President, and was elected.

I have served as President of the Branch during this turbulent year not so much because I wanted to, but rather because I felt a commitment to many of you. I have tried not to deviate in any way from my original goal: to help the Club grow and bring the NOC to all interested Norton enthusiasts. At many of our recent meetings I have felt that someone should represent that large, but silent, majority that doesn't attend Club functions. If the President wouldn't do it, I reasoned, who would? It hasn't been fun, but the words of thanks that have come my way from many of you have made it all seem worthwhile.

I feel that the recent ballot vote has resolved all of our major controversies, and the future of the Branch looks bright. There is a lot of good talk out there and I am confident that the Branch will elect able officers to guide it through the next year. May they have smoother sailing all the way. Merry Christmas to all of you, and have a Happy Norton New Year!



For those who missed the September weekend ride, here are a few photos kindly provided by Gerry Reynolds. *Bob*

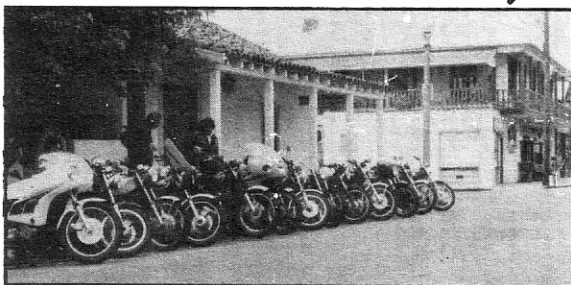

Saturday lunch Bunch at Jardines in San Juan Bautista.

Sunday morning pre-ride check-out before a brisk ride down the coast for breakfast. Gene Austin distracts unsuspecting Norton riders while Harvey Loucks looks for spares.

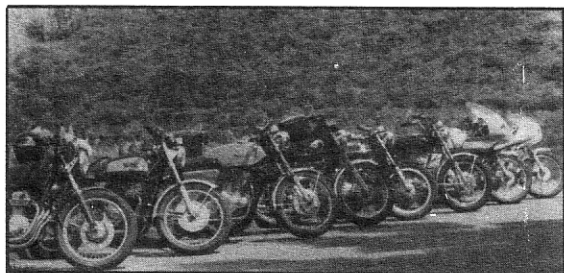
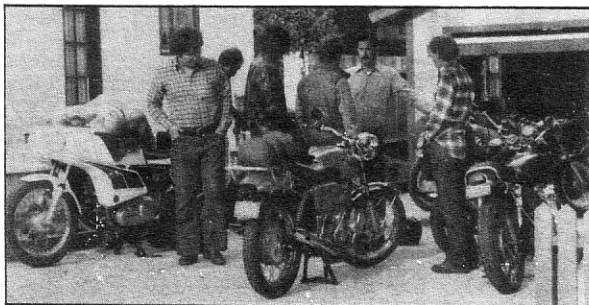

Sunday morning inspection 30 miles south of Big Sur at Mill Creek.

At Mill Creek with Limkilm Bay in the background, serious Norton riders take a breather.





The Newsletter of The Northern California Branch

Minutes for the meeting of the NOC Northern California Branch held Nov. 13, 1980.

Meeting was held at the London House in Palo Alto.

Steve Coburn announced that Art Sirota had foolishly volunteered to be secretary and take minutes at each meeting. This was followed by a discussion concerning the interpretation of the recent voting. Yes, we are going to accept out of state memberships, but we are going to be cautious about encouraging or recruiting new out of state memberships. January is to be election time every year. We agreed to develop a limited spares scheme. Yes, we will begin a tool loan-out program.

A discussion followed concerning whether the position of Editor of the NN should be appointed or elected. Because the job is almost too taxing for one person, it was decided that a staff situation, like the one presently being employed, is most favorable. There are to be no elections, but anyone who wants to help out may feel free to do so.

Nominations for elected officers will be taken at the next meeting. All members attending the Christmas party/meeting may nominate others.

The person who is willing to be the co-ordinator for the limited spares scheme may volunteer. If more than one person volunteers, then the persons may work together. Their names are to be published in the NN.

Maya has volunteered to organize this year's Christmas party but needs help with the food, decorations, etc. It is to be held at the Edinburgh Castle on Friday, Dec. 12. We have agreed not to bring our own booze.

Next, a discussion was held concerning the following Sunday's ride. Meeting place and route were discussed.

Mark Scardina won a copy of Bob Holiday's The Unapproachable Norton which was donated by Milestone Autobooks. The raffle tickets cost 50¢ and proceeds are to benefit the club treasury.

Art Sirota discussed the possibility of organizing a display of members' Nortons at a local shopping mall and was encouraged by the members to do so.

Jerry Henry announced the availability of new Norton digital clocks in various colors.

Meeting adjourned.

Art Sirota



PALO ALTO YAMAHA

YAMAHA • TRIUMPH • NORTON

SALES • SERVICE • PARTS

3960 EL CAMINO
PALO ALTO, CA. 94306

415 493-3414

Norton PARTS AND SERVICE

GARY BROEDER: EXPERT MECHANIC
N.O.C. MEMBER

Although not emphasizing British bikes on the salesroom floor, PALO ALTO YAMAHA has one of the bay area's best British motorcycle mechanics back in the shop. Gary Broeder knows as much as anyone in the area when it comes to making NORTONS run right. With his racing experience, Gary can work wonders on your machine when it needs help. I highly recommend PALO ALTO YAMAHA the next time you need a good mechanic for the old NORTON.

Brooks Cyclery

TRIUMPH
NORTON
BSA

NEW AND USED PARTS
TELEPHONE 295-4341
(408)

MOTO-GUZZI
DUCATI

ED BROOKS
OWNER

1615 ALMADEN ROAD
SAN JOSE, CA. 95125

BROOKS CYCLERY HAS BEEN A NORTON DEALER EVER SINCE 1948 AND IS STILL SERVING THE BAY AREA WITH A COMPLETE STOCK OF NEW NORTON PARTS, TOOLS AND ACCESSORIES FOR YOUR NORTON.

- * ED BROOKS - OWNER - 31 YEARS
- * BOB RABER - PARTS - 20 YEARS
- * BILL MANKINS - SERVICE - 12 YEARS

IN ADDITION TO ALL THE OTHER GOODIES IN STOCK BROOKS IS NOW OFFERING LOCALLY MADE MUFFLERS, HEADER PIPES AND 2 INTO 1 CONVERSIONS FOR ALL COMMANDO MODELS. THESE MUFFLERS ARE ACTUALLY BETTER THAN THE STOCK 750 TYPE AND LOOK VERY SIMILAR. CURRENT PRICE IS 20% BELOW STOCK.

MR. BROOKS HAS RECENTLY JOINED THE NORTON OWNERS CLUB, AND WELCOMES ALL MEMBERS AT HIS SHOP FOR A CUP OF COFFEE AND SOME GOOD NORTON TALK. STOP BY AND GIVE HIM SOME OF YOUR BUSINESS, OR JUST STOP BY TO TALK AND CHECK OUT THE BEAUTIFUL OLD MOTORCYCLES HE HAS ON THE SHOWROOM FLOOR. IT'S WORTH IT.



cycle sports

NORTHERN CALIFORNIA'S

Leading Norton Dealer

IN & ON NORTONS SINCE 1970

SALES * PARTS * EXPERT SERVICE

dunstall
POWER

NOW CLOSING OUT
DUNSTALL ODDS & ENDS
35% TO 50% off

2355 EL CAMINO REAL

AT SAN TOMAS EXPRESSWAY

SANTA CLARA, CALIFORNIA

(408) 247-1313

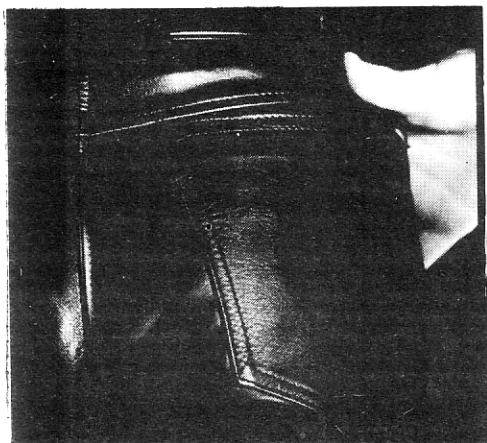

TAUBER'S LEATHERS

CUSTOM RIDING APPAREL
FOR THE MOTORCYCLIST

126 SUTTER

392-1462

SAN FRANCISCO

NOVEMBER'S BRANCH RIDE

It's hard to believe Winter is here, but the usually cold wind and rains haven't driven us Norton riders inside for our quick Winter rebuilds. This month's Sunday ride was typical of what it means to ride Nortons in Northern California; the weather was perfect (cold and dry) and the 20 or so Nortons taking off from Alice's Restaurant, where they tended to dominate the bike scene usually held by Asian beasts, quickly found the curves familiar and a long chain of British Iron was headed for the coast.

After a quick left onto stage road, the pace of the ride changed quickly to a slower beat, but only because the tighter curves on the narrow old asphalt. The riders must have felt the same way - this road must be like the ones Roadholder was made to run, and win. Rarely, one could take a quick glance to the west and see the cold, grey Pacific pop into view only to disappear again around the next turn.

A quick left a Pescadero and the Norton chain was ducking in and out of the redwoods again, climbing back into the hills.

Boulder Creek was the scheduled stop where most of the crew enjoyed a champagne brunch of Eggs Benedict, omelets or other such delights and no one seemed to go away hungry. Frank Ambrosi met the ride at this point (he lives just down the road) riding his less-than-factory-fresh but still-on-the-road 1949 Manx which was a rare treat for many.

With still much more riding ahead, the group reluctantly gathered for a quick sprint for the Pacific where one of the usual Norton ride phenomenon takes place - the Impromptu Tech Session. This is where everyone stops, no one has broken down or lost parts, but a session where riders gather around machines, almost like a snap inspection, and the bikes are pondered and picked over and more information is passed about Nortons than all the rest of the day. But, it is soon time for all to split up and ride their individual courses home and to spend a little time alone with their machine on the road.

Harry Hardturn

NOTE: Any frustrated, would-be writers whose high school English teacher said you'd never be published, are encouraged to share their point of view in writing about rides or personal experiences on the road. Even anonymously.

"The Unapproachable"
LONG STROKE
NORTON



The Newsletter of The Northern California Branch

TECHNICAL SECTION

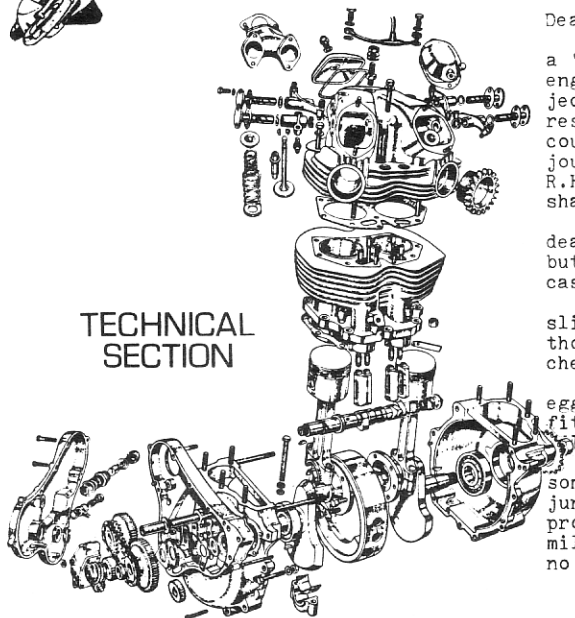

The following is an updated list of oil filters that fit Nortons:

Mann	W712/9
AC	SW
Purolator	FC103
G.U.D.	Z102 or Z64
Crossland	631 or 673
Parflux	LS131
Fram	PH2839, PH2873, or PH2864

These filters should be available from better auto parts houses and imported parts stores, although they won't be cheap. Don't be discouraged if the guy behind the parts counter says "That number doesn't exist" because I have seen the first seven filters installed on Nortons. In case you are interested, the automobile application for the filters is for 1000, 1100, and 1200cc Simcas and the thread size is 16mm x 1.5mm.

About six months ago I took the oil filter mount off my 850 and gave it to a former member of this N.O.C. branch, Bob Stiglitz, who proceeded to machine the threaded center post to accept an internally and externally threaded bushing that he made. I now use an easily obtained filter that is for the General Motors 231ci V-6's that has the same outside dimensions as the expensive Norton filters. Can you imagine paying \$1.99 (or less) for a filter on sale?

Gene Austin

Dear Editor;

I don't know if this is actually a 'technical tip', but my Commando engine when purchased had been subject to severe owner neglect. As a result, the timing chain tension could not be adjusted properly. The journal for the idler shaft in the R.H. crankcase was worn to an egg-shape.

My nearby, prominent Norton dealer said there was nothing for it but to purchase a new pair of crankcase halves. Ouch!

I'm no machinist, but with my slight grasp of the subject I thought there might be a better, cheaper alternative.

A local job shop milled out the egg-shaped journal and shrink-fitted an aluminum sleeve for the idler shaft (also a shrink-fit).

The whole job cost \$18.00 and some legwork on my part. Don't junk your cases if you have this problem. I've got nearly 10,000 miles on my 'rebuilt' cases with no problem.

Yours for torque,

Bill Breitzmann

P.S. Call me if you need a machinist recommendation! (408) 248-0571

SPARES SCHEME UPDATE

After 10 months of struggle the No. Calif. N.O.C. Branch is slowly moving towards establishing a co-operative buying effort along with a real spares scheme for it's members. Having offered to help get this program off the ground way last February I'm going to keep my promise and assist Jerry Henry and Jeff Pierce get it rolling. These 2 members have offered to form a spares committee. It will of course need help along the way if this program is to be a success. If you would like to help out with the Branch's activities, this would be perfect. It will probably be a bi-monthly service with only a few hours work each 2 months. You won't have your head in a yoke for hours of work each month. I see this as a very important and relatively easy job, one which will probably have more volunteers than needed-so step up now.

Before the Branch starts off on this project I think it would be a good idea to set up a framework. Your ideas are important and I foresee a lively discussion at the January meeting. I will propose the following to be voted on at the meeting. It can be amended through discussion to reflect the wishes and needs of the members. Once we establish the policies all members will know what is required of them to participate.

The Newsletter of The Northern California Branch



"The No. Calif. Branch Spares Scheme will be administered primarily through the monthly meetings. The service will be available to full N.O.C. members only. Associate members are encouraged to pay the 7 pounds to become full members and avail themselves of the Spares Scheme and Roadholder magazine. At the meeting the member's order and money to pay for the parts will be received by the Spares Committee and club Treasurer respectively. The orders will be collated into one order for Les Emery and dispatched. When the parts arrive the Committee will bring them through customs and the treasurer will dispatch payment for the parts that have actually been received. This will allow refunds for parts not in stock rather than having a credit in England. Parts will be disbursed at the next meeting."

Obviously there is a lot of room for discussion and it should take place before the program begins. Bring your ideas and self to the Edinburgh Castle.

To whet your appetite for all this I'll relate a recent purchase. A month or so ago I wrote to Gander & Gray in London concerning purchasing Boyer ignitions. They indicated a 5 unit purchase would secure an additional 5% discount after our 10% N.O.C. discount. 4 other members and I ordered the units on the 24th of October. Gander & Gray sent the units off on the 11th of November. They arrived in S.F. on the 19th of November. Total cost per device including air mail, customs and bank draft: \$73 each!

Let's get this show on the road.

I wrote to Les Emery concerning the quality of parts the Spares Scheme supplies and about the details involved from his end. This is his reply. Another letter to clarify VAT and the like is on its way back.

Dear NOC'ers:

Thanks for the letter and interesting newsletter. Just to put your minds at rest, I hope, Interstate tanks are genuine steel. Pistons are Hepolite (except short stroke 750 pistons which are Omega). Layshaft roller bearings are either SKF (who supplied Norton) or STEYR (who make PUCH bikes.) I can't say whether the valves are stellite tipped like the old chrome stemmed variety, but we buy them off Andover Norton (which is part of NVT!)

All parts that we supply are guaranteed to be suitable for the job they were supplied for and are genuine Norton parts where possible. Faulty parts (Yes, we're not perfect) will be replaced free of charge and postal costs refunded. In certain cases, (i.e., plain Commando clutch plates) we buy direct from the maker to cut out the middle man. We sell plain plates for 1.40 lbs. - Norton price is 4.30 lbs!!

Many of the pre-Commando parts are made through my shop and not the NOC because the Club hasn't the cash to spare and I have. This doesn't affect the price or quality but means I can keep an eye on all stages of production.

From a personal point of view, I don't care whether I sell parts to NOC or non-NOC members - as long as the non-member is prepared to pay the 20% extra!

When we send goods to other countries we still charge VAT and the member pays that much less Import Duty - I'll contact the Customs and Excise on this.

Due to the fact that we add such a small profit margin onto the price we pay, we are at the mercy of any rises because we haven't got a buffer to absorb them. This means that listed prices are constantly out of date. I feel the best way of buying parts off us is to send an order without money and for us to send the parts we have in stock (which is 97%) with a bill for parts plus whatever the post costs. This is better because faulty, unsuitable or unwanted parts can be returned with the money. It costs a lot less to post one big order than several small ones, and air mail is at least twice as much as sea freight. However, we'll try to keep costs as low as possible at our end and pass on any special deals we make. Air Freight takes from 3 to 8 days, and Sea Freight 5 to 7 weeks.

I'll talk to the Committee meeting on Sunday (31st) to see if they'll share the cost of postage!

Let me know your views on all this.

Safe riding,

Les Emery



The Newsletter of The Northern California Branch

On Sunday, November 15th, 1979, a 1974 850 Norton Commando owned, built, and ridden by Mark Ingalls or Orinda, California, took 1st Place Overall in the 200 mile AFM Sears Point Endurance Race II, winning by nearly 2 laps and going away. Mark and his Norton outrode a field consisting of several AMA superbikes: Suzuki GS 1000s, Kawasaki Z1s, Hondas, BMWs, Ducatis, and so on. Winning superbike riders were there, like Gordy Seim with the latest. Many people called Mark's victory an upset, but to those who know Mark and his Norton it was a vindication. It was victory because they work well together. Mark started the race in the third row, out of a field of more than 100. When the flag dropped, he broke away with the leaders and never look back. He was soon in 3rd place, racing fast and smoothly, and never more than 12 seconds from the lead bike. By the 5th lap, mark had dropped his time to the low 1:57. No one was taking it easy. Some riders made early pit stops, others stretched their bikes and abilities too far and crashed.

As time and speed took their toll, the really good riders started some very exciting racing, Mark and his Norton fought with Dan Battcher's very fast Triumph. Dan had won the Sears Point Endurance I 750 Class honors a year earlier, not too far back from Mark's 2nd place finish in the Overall Open Class.

As Dan's Triumph battled with the Norton for the next half hour, they exchanged 2nd and 3rd spots on and off. The traffic spaced out. For a British enthusiast, it was truly beautiful; for the rest of the spectators, it was entertainingly good racing.

By lap 30 Mark was trailing Dan as the intensity eased. On lap 33 the Triumph pitted for gas, and new rider Dave Matthews came out on the Triumph and began to catch up. Unfortunately, the super-tuned Triumph was not long for this world, going out with a busted crankshaft that made oatmeal out of its innards.

The race progressed. Mark's time remained 1 to 1.5 seconds off the leader. He held 3rd convincingly with little pressure from behind.

= RACE WRITE-UP BY

STEVE FREI

&

MARK INGALLS =

Then, by the mid-30s the big bike favorites began pitting. 3rd place took over 30 seconds, first pitted in a well-rehearsed 12 or so. Mark kept right on going--in 1st place. By the end of the first 40 lap 100 mile leg, Mark was only 4 seconds back in second place, and he still had plenty of insurance gasoline in the tank. Probably about 10 oz.

After 100 miles of 110% racing, the bike required only a rewrapped exhaust safety wire. The brilliant, cool day was perfect English racing weather, and the Norton seemed to smile with satisfaction.

The pits buzzed. Racers nodded to Mark with familiar friendly encouragement. Stray visitors stopped and stared. Superbike teams worked furiously, occasionally glancing over their shoulders. They wouldn't get too many more chances to see him from that perspective.

The 1st leg leaders, a GS 1000 and an AMA superbike Kaw Z1 were 1, 2 at the start of the 2nd leg. Mark was not far behind

"I was 3rd into the first turn," Mark says, "chased Seim on the Z1 and Klinzman's Racecrafters Z1. Seim fell down in turn 2, Klinzman slowed, and I took the lead on the first lap."

Klinzman passed Mark for the lead, then pitted 4 laps later with a loose exhaust pipe. Mark was again in first place, the Norton taking the lead to stay. By lap 65 Mark had passed everybody once and was playing with the 2nd place Kawa 650. He lapped him for the 2nd time.

Mark relaxed a bit with the 2nd place bike 3 seconds behind. The laps went by, and Mark stretched his lead, finally winning by almost a full lap. It was magnificent.



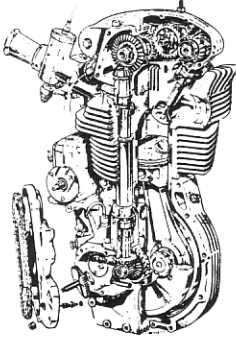

TRADING POST

For Sale: NORTON Tube Tops for Ladies, one size fits all. Black NORTON logo on; white, red, yellow, red w/blue cuff. Specify first and second choice. \$5.00 plus \$1.00 for postage and packing. Checks OK

Adrienne Skillington
150 Borica Way
San Francisco, Ca.
94127

FOR SALE: 1975 Commando 850 Roadster. Excellent condition. Black. \$1895. Dennis Powell. (415)636-1798 in the evening.

FOR SALE: 1975 850 Commando. Electric start, Black w/ Gold Pin-stripes, Interstate Tank. Very clean. Matching fairing and side bags. \$1300. Call Dave at 322-1666 in the evenings.

For Sale:

1975 Mk III roadster, black, 9,000 miles, \$1600 o.b.o.
1968 Atlas, engine just rebuilt, frame just painted, all original except fenders, \$800 o.b.o.
Norton flat track, \$1500 o.b.o. (I've seen this bike and it's very sharp.)
Ralph (213) 363-9130 home
(213) 785-6093 work

Wanted:

Lucas turn signals, particularly the plastic ends, in good condition.
Slimline featherbed rolling chassis or basket case in good condition.
Gene Austin (415) 573-9559
afternoons and evenings.

FOR SALE:

- 1) New black/gold Roadster tank seat and side covers. Immaculate-\$125
 - 2) Fastback seat for Interstate tank configuration-\$25
 - 3) Avon 4.10-19 practically new-\$20
 - 4) Set of new intake and exhaust valves for 850-\$45
 - 5) Set of Girling shocks/springs, practically new-\$40
 - 6) Norton stock horn-\$6
 - 7) Fork gaitors, set-\$6
- Call Dick Swanson at 644-4675(W) or 922-5993(H).

FOR SALE: 1969 ATLAS 10K. MILES
\$1800
1969 N15(750cc.)
\$1650 12K. MILES
1966 G15(750cc.)
\$1600
ABOVE BIKES REBUILT AND IN EXCEL.
CONDITION. ALSO PARTS FOR SALE.
785-8447

NORTON-P11

- Front and rear wheels (pair only), clean - \$100
- Oil tank, replacement-type, new, candy apple red - \$50
- Fork tubes and sliders, used but good - \$50
- 1 pair coils, used - \$20
- Exhaust pipes, used but clean \$40
- NORTON Scrambler
- Frame, clean - \$100
- Exhaust pipes, good - \$30
- Oil Tank, good - \$30
- MODEL 99
- Engine cases, generator type - \$50
- Crank shaft, gen. type, fresh grind .10 under with inserts - \$100
- Distributor - \$50
- Seat, original cover, very clean-\$50
- Seat, frame and foam - \$30
- Oil tanks, (2) - \$15 each
- Tool and battery box - \$15
- Headlight w/ speedometer - \$50
- License plate bracket - \$25
- Footpegs with shaft and spacers-\$20
- Primary covers, gen. type - \$35
- NORTON ELECTRA
- Too many parts to list, 2 complete motors, many parts - all very cheap
- Main bearing extractor, Norton Part No. 063970, new - \$100

Call Gorden at (415)428-1940 or 548-7786

T. T. Motors

2800 Adeline • Berkeley, CA 94703
(415) 845-8235

NORTON ENTHUSIASTS: We specialize in Early and Late Commando Parts, and we offer a complete Service and Machine shop for your Norton work.
STOP BY AND VISIT - CHECK THESE ITEMS OUT!

- * COMPLETE LINE OF BRITISH TOOLS
- * NEW BLACK ROADSTER TANKS
- * FACTORY WORKSHOP MANUALS: MKII & MKIII
- * COMPLETE GEARBOXES, CASES AND GEARS
- * SPEED EQUIPMENT:
 - MEGACYCLE AND NORRIS CAMSHAFTS
 - PM RACING VALVE SPRINGS AND GUIDES
 - BRANCH RACING VALVES
 - SINGLE MIKUNI KITS

- *SERVICE DEPARTMENT--BUILDING AND MODIFICATION OF STREET AND RACING MACHINES:
 - EXHAUST PORT REPAIR
 - VALVE JOBS
 - CYLINDER BORING
 - HEAD MILLING AND SURFACING
 - MAGNAFLUX
 - AND MUCH, MUCH MORE!!!

*FINALLY WE OFFER A 10% DISCOUNT ON ALL NORTON PARTS TO MEMBERS OF THE NORTON OWNERS CLUB
(Service work is not included)

MOTORCYCLES UNLIMITED Sales and Service

ALEX S. MCLEAN
OWNER

(415) 924-0327
5776 PARADISE DRIVE
CORTE MADERA, CA. 94925

Motorcycles Unlimited is the West Coast distributor for Dunstall.

Complete stocklists for:
Dunstall

Rear Sets	Valve Springs
Silencers	2-1-2 Center Stand
Gas Tanks	Clip-ons
Cylinder Heads	Oil Feed Line
Front Fenders	G.T. Pairing Replacement
	Windshields

Plus a full supply of stock Norton bits.

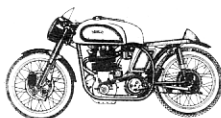

Classic Nortons on display.

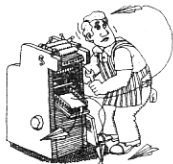

GEORGE

239-0110

Low Cost Printing
to Schools, Churches
and Non-Profit
Organizations

**selby
motors**

- motorcycle sales
- self service
- accessory dept.
- complete service dept.
- machine shop
- insurance
- notary service

See Jack Morris, a branch member and Norton enthusiast for quite a few years, if you're looking for parts or accessories. Jack's got the goodies and will take the time to make sure you get exactly what you need.

Selby's service department is in the able hands of Alan Hook, an experienced Norton mechanic and also a branch member. If the Norton isn't running right and you're unsure about what to do, take it to Alan and he'll see that it gets back into tip-top shape.

346 El Camino Real
Redwood City, Ca. 94062

(415) 369-4112