



# Norton Notice



The Newsletter of The Northern California Branch

VOLUME 3 ISSUE 5

MAY 1980

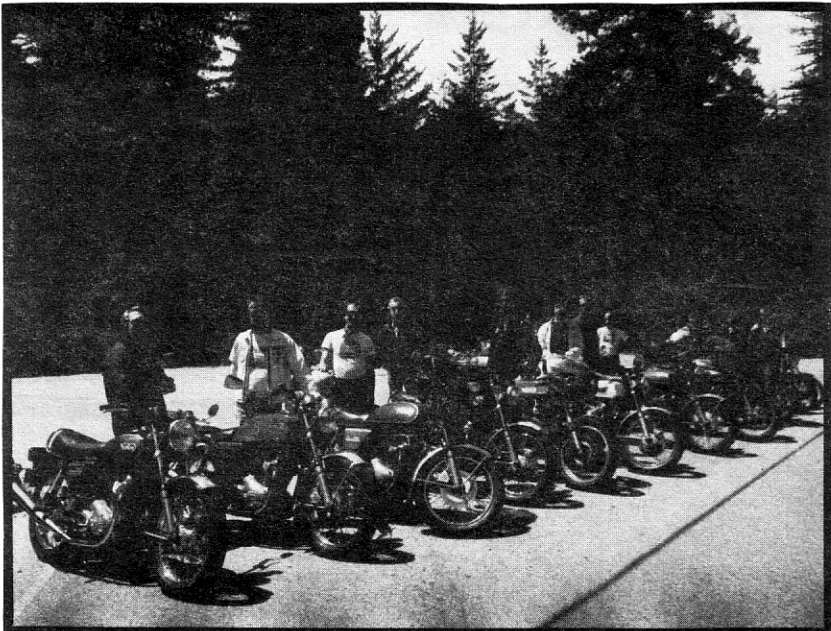

## NORTON OWNERS ON THE APRIL RIDE

Published monthly by the  
Northern California Branch  
Norton Owners Club





# The Newsletter of The Northern California Branch



Published monthly by the Northern California Branch, Norton Owners Club

## BRANCH OFFICERS

### PRESIDENT

Steve Coburn  
P.O. Box 236  
La Honda, CA 94020  
(415)747-0326 Home  
(415)497-6601 Work

### SECRETARY/TREASURER

Carollyn Scott  
1970 Latham #14  
Mountain View, CA 94040  
(415)968-5117

### NORTON NOTICE STAFF

Michael Heth  
87 Ord St., Apt. 3  
San Francisco, CA 94114

Meda Rago  
Copy Ed., Typist,  
Proofreader

Dick Swanson  
Special Technical Projects

Brian Halton  
Special Projects

Club business is best handled through the mail--especially material of any sort for the Club Newsletter. Use the above addresses.

## BRANCH MEETINGS

Generally held the second Thursday of each month at a location announced in the NOTICE.

## BRANCH RIDES

Rides are generally held the following Sunday at 10:00 am at a location announced in the NOTICE. In the event of rain the ride will be postponed 1 week. Occasionally, rides are on a Saturday or over the whole weekend. Check the NOTICE Calendar each month.

ODD BODKINS (Reprinted with permission)

There are three categories of membership in the Northern California Branch of the N.O.C.:

**FULL MEMBERS:** Full members are dues-paying members of the N.O.C., and therefore have full voting privileges at any general meeting of the N.O.C. and all branch meetings, and also any privileges resulting from affiliation of the Club with any other organization. Full members must pay annual dues to the N.O.C. in England (paid through the Secretary), in return for which they will receive the bi-monthly ROADHOLDER magazine and may use the N.O.C. Spares Scheme at any time.

**ASSOCIATE MEMBERS:** This category was set up so that any Norton owner wishing to get the NORTON NOTICE each month and be associated with the Northern California Branch can do so for a very modest fee, without having to join the N.O.C. as a full member. Associate members do not pay N.O.C. dues, and therefore do not have all the privileges of full N.O.C. members. They do, however, have full voting privileges at all Northern California Branch meetings and are equally welcome at all of the rides, meetings, and other functions sponsored by the branch.

**SOCIAL MEMBERS:** In order to allow Norton enthusiasts who do not own a Norton to be associated with the Club and thereby help them to find one to buy, the branch provides the category of 'Social Membership'. Social members do not have any voting privileges but are otherwise welcome to participate in all branch activities. Social members will receive the NORTON NOTICE each month and are encouraged to follow up on any leads regarding Norton motorcycles for sale. The Editor will try to help all social members in this regard and would appreciate any help from other members.

## CURRENT DUES PAID AND PUBLICATIONS

	<u>RECEIVED</u>	<u>PAY</u>	<u>RECEIVE</u>
FULL MEMBERS	\$25		<u>NORTON NOTICE &amp; ROADHOLDER</u>
ASSOC. MEMBERS	\$10		<u>NORTON NOTICE</u>
SOCIAL MEMBERS	\$10		<u>NORTON NOTICE</u>



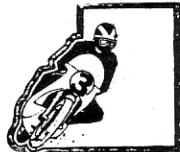

# THE EXHAUST NOTE



Hello to Everyone,

I hope you've all been getting in some good riding this last few weeks with the good weather. The last ride was on a beautiful day, and hopefully, it shows in the cover picture. This is the first photo processed by me in the ol' makeshift darkroom. I'm hoping it will cut our costs a bit and allow us to do some special issues on the various models of Norton. Look for that in the future.

*MM.*

## A VIEW FROM THE PILLION POST

On my first motorcycle ride I spent most of my energy on fooling the driver into thinking I knew what I was doing. It's not really hard to be an adequate passenger, but it's far more entertaining and satisfying to really participate. In this column I hope to consider topics from one passenger's personal point of view in the hope of fostering that degree of participation. This month: "The Effect of the Passenger".

I noticed on the last Club ride around the hills near Woodside, that the bikes tended to group themselves by speed. Any of several factors determine how fast a particular driver goes: the bike's power, the driver's experience, the road conditions, familiarity with the route, hunger, etc. It was something of a surprise to me that whether or not a passenger was aboard did not seem to affect speed. I expected the extra weight or the concern for another's safety to hamper those riding double. No, the couples were ranged along the length of the entourage.

I hope driver and passenger agree on speed--it doesn't have to be a verbal pact, just an understanding. Once this is worked out, there are several ways a passenger can ride and move in order to give the driver the greatest freedom in determining and controlling that speed comfortable to both.

First, many drivers prefer to be hugged around the waist because this allows the best judgement of weight placement at any given moment. This applies to men riding together, too. Be daring. Be European. Ride close. At least, ask your driver for his/her preference.

Use your legs in a manner similar to horseback riding. Don't come down hard over the road bumps and pot-holes. Try to anticipate them and stand a little on the passenger footpegs. It's great exercise for the thighs.

Watch traffic. Be especially alert at intersections so that you can lean to the side opposite to oncoming vehicles. Between the limited visibility of the helmet and the management of the machine, the driver is busy enough without the added confusion of helmets cracking together. (This happens to me a lot at stops and starts.)

I'm sure those who ride together on the same bike regularly have worked out arrangements to afford them maximum fun and comfort. The ones I've described here have helped me. Perhaps you'd like to add them to your riding repertoire.

Meda Rago

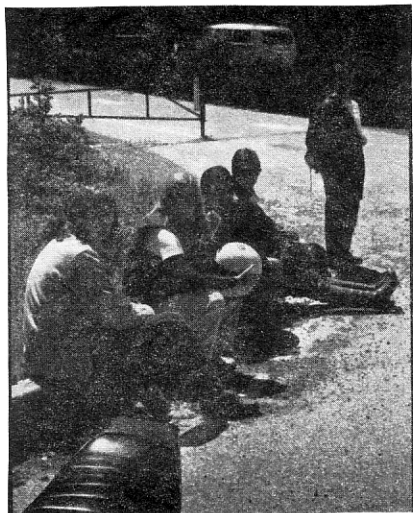

## PILLION PASSENGERS IN REPOSE



# Norton owners club

Please reply to:-

Stephen C. Coburn  
President - N.O.C.  
Northern Calif. Branch  
P.O.Box 236,  
La Honda, CA 94020

Date:  
April 25th, 1980

May greetings to all Northern California Branch NOCcers!

Lots of things are happening these days on the Norton scene, and I hope more members who may not have been active in recent months will come out of hibernation and join us for some of the Norton happenings in the weeks and months to come. By the time this issue goes to press, several members will be on their way down to Lancaster, on the edge of the Mojave Desert, for the 1980 CAMA Rally. In addition to eyeballing and drooling over all the pristine classic and antique bikes that show up at CAMA every year, we will try our best to be representative of the Branch membership as a whole when we select this year's lucky winner of the "BEST NORTON" trophy. No doubt Marshall Van Tassel, whose beautiful 1956 Manx took the award last year, will be back again for another shot. I've got a feeling, however, that he's going to be facing some stiff competition this year. Look for a complete report and photographs of the winning Nort in the June Notice.

This month's Branch meeting will be Thursday evening, May 8th, at the Redwood Inn up in the Oakland hills. Hopefully a lot of you East Bay members will show up this time, or we might seriously consider having all future meetings in San Francisco and Palo Alto where we always get a good turnout. It's up to you. For those of you who've never been there, the Redwood Inn (6415 Redwood Road, Oakland) is a great place for dining and/or drinking and now that the weather's getting better we'll probably be outside in the beer garden that evening. Should be a lot of fun for all who show up. I hope to see you there.

The ride this month has been organized by Bart Rago, who tells me we'll be going up into the Sacramento River delta, taking mostly two-lane roads all the way, and ending up in Locke for lunch. If you've been there before, I know you'll want to come. If you haven't been to Locke, come along with us and see something you probably never knew existed any more. It's really interesting, and the levee roads make for some great spring riding. So put Sunday, May 11th on your calendar as "N.O.C. Ride Day", and we'll see you then. All details about the meeting and ride should be in the "EVENTS" list elsewhere in this issue.

My next bit of news may or may not be of interest to any of you, but I'm so excited about it I'm going to tell you anyway. On or about May 20th I'll be leaving for three to four weeks in England, at least one of which will be spent on the Isle of Man. I've wanted to experience T.T. Week for quite some time now and this year the opportunity has finally presented itself. Although I hope to spend most of my time in England touring around the countryside on a Norton I plan to buy or rent, I will be in London for at least a few days and would be happy to pick up any small items I can for members of the Branch. I know that the N.O.C. Spares Scheme sells electronic ignitions (Boyer, I believe) at a price far below those we see over here, so if anyone's interested, give me a call. I'm told there are quite a few goodies readily available in England that we never see at all in the U.S., so if there's something you've been looking for unsuccessfully, just let me know. I would be most interested in any names, addresses, telephone numbers, etc. of good friends over in England who might have a spare bed or whatever for a wayward Yank. I will be traveling on a budget, so all help and suggestions will be most gratefully accepted. THANKS!

Finally, I want to encourage everyone, and I do mean EVERYONE to save Sunday, June 15th and not make any other plans. I know it's Father's Day, and what better day for the 4TH ANNUAL NORTON BEER BUST? Tom Skillington's excellent Beer Bust flyer, included with this issue, has all the details. If you have any questions about this event, the site, etc., please give me a call before May 15th. I'm hoping to be back from England in time because I sure don't want to miss this one. You shouldn't miss it either! I'd like to extend a special "Thank You" to Tom Skillington, who not only did the artwork for the flyer, but also donated the printing costs out of his own pocket. Thanks from all of us, Tom!

KEEP ON NORT'N!

*Steve*

scheme and can offer the following:-

I wish to join /re-join the

ACCOMMODATION \_\_\_\_\_ TRANSPORT \_\_\_\_\_ GARAGE \_\_\_\_\_ TOOLS \_\_\_\_\_ SPARES \_\_\_\_\_

NAME \_\_\_\_\_ MEMBERSHIP No. \_\_\_\_\_

ADDRESS \_\_\_\_\_

TELEPHONE \_\_\_\_\_



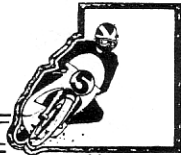

# Norton Rally In The Redwoods 80

DON'T BE ONE  
OF THE FEW WHO'LL  
MISS THE NORTON  
RALLY THIS YEAR.  
PRE-REGISTER NOW!

STEPHEN COBURN  
P.O. BOX 236  
LA HONDA, CA. 94020  
(415) 747-0326 - Home  
(415) 497-6601 - Work

April 23, 1980

To pre-register for the Rally in the Redwoods, send \$16 per adult

### USNOA Rally Update

Many members of the Northern California Branch - N.O.C. have sent in their pre-registration checks for this year's USNOA Rally. All those who have not yet done so, but are planning to attend, are strongly encouraged to pre-register no later than July 15th. It is very important to know how many people are going to be at the Rally so that we can order the right amount of beer, food, etc., and if you pre-register it also helps the people working at the registration desk when you actually arrive. If you plan to do no more than just show up and enjoy the Rally, at least help us out by pre-registering. THANKS! Some of you might possibly be thinking about missing this Rally...BIG MISTAKE! If you've never been to a Norton Rally, you just don't know what you're missing. If you miss this one, you'll have to read all about it in the Norton Notice in the fall, and you'll be kicking yourself for not coming. So, why not decide right now that you're going to take a couple days off (August 7-10) and enjoy some real Norton camaraderie up in Leggett. There's no doubt that next year's Rally will be back east somewhere and there probably won't be another on the west coast until 1984. I would recommend that you come to this one, since none of us has any idea where we might be four years from now, right? Think about it.

Moving right along, it has recently come to my attention, from a very reliable source (Brian Stark), that the AMA in all its wisdom has decided to change the format of this year's Laguna Seca motorcycle race meeting. What would have been a full weekend of racing, including vintage races, etc., will now be a one-day "National" on Sunday, August 3rd. Needless to say, it will attract all the best roadracers in the country, and for those of you who enjoy watching guys ride very fast (albeit on Jap bikes), it will be a real thrill and a half. The planned Norton gathering is still on, and people en route to the Rally are especially encouraged to stop at Laguna Seca (near Monterey) that day on their way to Leggett. Look for further announcements about this and other Rally plans in the next Notice.

KEEP ON NORT'N! *Stark*

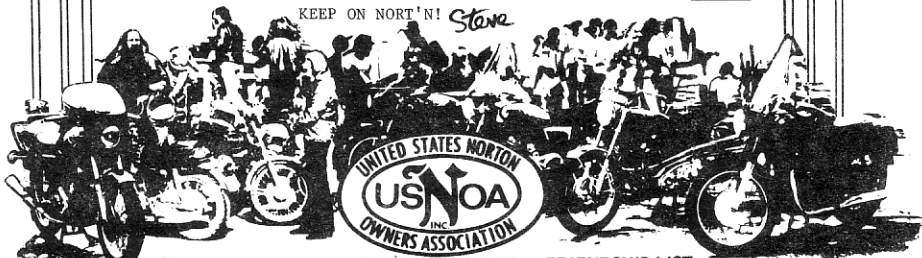

### NORTON OWNERS CLUB, EMERGENCY AID - FRIENDSHIP LIST

Dear Member,

The Club's 'Emergency Aid List' is there to help YOU. Just fill in the form below and return it to me and I will send you a list of members who are in the happy position of being able to help fellow members who are in need. It is not important that you offer all the facilities mentioned but it is important that you mark clearly (X) what you can offer. PLEASE give membership number.

- Accommodation - Means simply that you can put someone up overnight, on the floor if necessary.
- Transport - That you are able to go to a break down and retrieve the victim, and possibly his machine as well.
- Tools - Tools.
- Spares - If none yourself, someone nearby who can help.
- Garage or Workshop - Merely that you can provide somewhere dry to work on the evil machine. Few Nortons break down (?) but it can happen to you, and in any case many new friends can be made through this list.



## CLUB EVENTS CALENDAR

DATE	TIME	PLACE	
5-8	7:30PM	Redwd Inn 6415 Redwd Rd, Oklnd 531-9935	May Nor Ca Brnch Meeting
5-11	10:00AM	Meet at Lake Temescal	May Nor CA Brnch Ride
5-18	11:00AM	Sears Point Sonoma	AFM Racing
6-1	11:00AM	Sears Point Sonoma	AFM Racing
6-12	7:30PM	Edinburgh Castle 950 Geary SF	June Nor CA Brnch Meeting
6-15	12NOON	Memorial Pk Pescadero Rd nr La Honda	NORTON Beer Bust

### May's Club Ride

Meet at Lake Temescal at 10:00 am.  
From SF: take 24 to Bdwy exit to parking lot. From Berkeley: up Ashby (past Claremont Hotel) to light, L, then R over fwy and R to parking lot. From points South: Warren (Fwy 13), go under Fwy 24, R at light, then X over fwy, R and proceed back down to parking lot. Yes, gas is within 5 minutes.

At 10:30 we fire them up and dial them in. Itinerary as follows:  
From Lake Temescal, 24E to 680N (9 mi); take first exit which is Ygnacio Villy Rd ( $\frac{1}{2}$  mi) to Clayton Rd (total of 17.5 mi). Go R down Marsh Creek Rd to Walnut Blvd (total of 36 mi), L to Brentwood (total 39 mi). R to get on Route 4 to 160 Sacto N (total 46.5 mi). 50¢ toll to go over new Antioch Bridge. N to Locke (total 72.9 mi) where gas is available even in a small town on a Sunday. The roads are flat but curvy and flirt with the river here and there. It's very scenic and warm, too.

Locke is a fascinating town to explore. It's a ghost town with a difference: it was Chinese. Founded in 1912 by railroad and levee workers, it once thrived with schools, theatres, markets. Today, the gambling house is preserved as a museum, and the faded buildings and wooden walkways still stand--harboring a few enterprises including a great steak sandwich house and a hamburger place both selling beer. See you then.

Meda & Bart Rago

## Norton

SPOKEN HERE

We stock a complete line of genuine Norton parts. Write for our accessory catalogue. 10% discount to members. VISA/Mastercharge accepted.

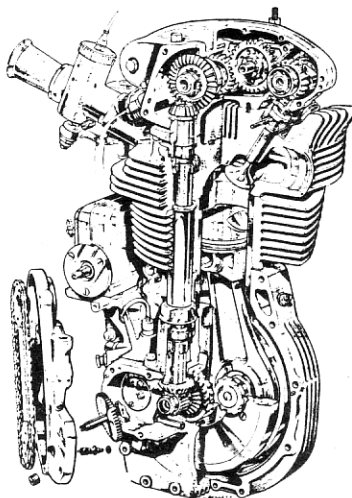

### BRIAN SLARK CLASSIC MOTORCYCLES

785 B West 17th Street  
Costa Mesa, CA 92627  
(714) 642-8411

## PALO ALTO YAMAHA

YAMAHA • TRIUMPH • NORTON

SALES • SERVICE • PARTS

3960 EL CAMINO  
PALO ALTO, CA. 94306  
415 493-3414

### Norton PARTS AND SERVICE

GARY BROEDER: EXPERT MECHANIC  
N.O.C. MEMBER

Although not emphasizing British bikes on the salesroom floor, PALO ALTO YAMAHA has one of the bay area's best British motorcycle mechanics back in the shop. Gary Broeder knows as much as anyone in the area when it comes to making NORTONS run right. With his racing experience, Gary can work wonders on your machine when it needs help. I highly recommend PALO ALTO YAMAHA the next time you need a good mechanic for the old NORTON.

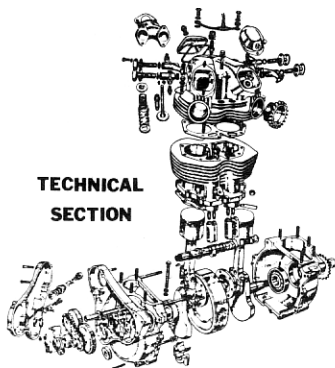
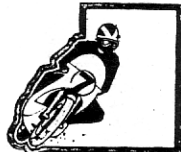

TECHNICAL SECTION

Whitworth also carried out similar experiments with cannon and came to like conclusions, as mentioned above.

His development of 'fluid-pressed steel', which he used in his barrels, and special techniques of arms production, enables the superior performance for which the Whitworth arms were famous. The student of firearms, especially those used during the Civil War, will at once recognize the Whitworth name. A small number of his cannon and rifles were used in the Civil War, mainly in the South. They proved devastating in the hands of sharpshooters, and in the protection of the blockade runners from Union ships in pursuit.

Whitworth was continually concerned with labour-saving devices and thus the elevation of general living conditions and the welfare of his countrymen. His views that men were limited in their prosperity by their ability to produce and consume the products of this economical production were confirmed by his visit to America in 1853. Here he observed American willingness to use machines and mass production wherever possible to replace manual labor. ". . . under the guidelines of superior education and intelligence, the remarkable prosperity of the United States is mainly due."

In light of the present economic situation in England, it is interesting to know that he contrasted the American abilities with the trade union opposition to mechanization in England. He felt that menial and laborious tasks could better be performed by machines and that machine operators would be paid more for their skills. ". . . the artisan should be free to earn all he can without the hindrance of his fellows." He also strongly urged that more leisure time would be available for education, upon which I will comment shortly.



**cycle sports**  
NORTHERN CALIFORNIA'S  
**Leading Norton Dealer**  
IN & ON NORTONS SINCE 1970

SALES \* PARTS \* EXPERT SERVICE

**dunstall**  
POWER

NOW CLOSING OUT  
DUNSTALL ODDS & ENDS  
**35% TO 50% off**

**2355 EL CAMINO REAL**  
AT SAN TOMAS EXPRESSWAY  
**SANTA CLARA, CALIFORNIA**  
**(408) 247-1313**

### Brooks Cyclery

TRIUMPH  
NORTON  
BSA

NEW AND USED PARTS  
TELEPHONE 295-4341  
(408)

MOTO GUZZI  
DUCATI

ED BROOKS  
OWNER

1615 ALMADEN ROAD  
SAN JOSE, CA. 95125

BROOKS CYCLERY HAS BEEN A NORTON DEALER EVER SINCE 1948 AND IS STILL SERVING THE BAY AREA WITH A COMPLETE STOCK OF NEW NORTON PARTS, TOOLS AND ACCESSORIES FOR YOUR NORTON.

- \* ED BROOKS - OWNER - 31 YEARS
- \* BOB RABER - PARTS - 20 YEARS
- \* BILL MANKINS - SERVICE - 12 YEARS

IN ADDITION TO ALL THE OTHER GOODIES IN STOCK, BROOKS IS NOW OFFERING LOCALLY MADE MUFFLERS, HEADER PIPES AND 2 INTO 1 CONVERSIONS FOR ALL COMMANDO MODELS. THESE MUFFLERS ARE ACTUALLY BETTER THAN THE STOCK 750 TYPE AND LOOK VERY SIMILAR. CURRENT PRICE IS 20% BELOW STOCK.

MR. BROOKS HAS RECENTLY JOINED THE NORTON OWNERS CLUB, AND WELCOMES ALL MEMBERS AT HIS SHOP FOR A CUP OF COFFEE AND SOME GOOD NORTON TALK. STOP BY AND GIVE HIM SOME OF YOUR BUSINESS, OR JUST STOP BY TO TALK AND CHECK OUT THE BEAUTIFUL OLD MOTORCYCLES HE HAS ON THE SHOWROOM FLOOR. IT'S WORTH IT.



A good illustration of his invention of a work-saving mechanism is his street cleaning machine, which used a series of brooms on an endless chain to sweep up debris into a cart. Used in Manchester, it was reported to have changed the town from one of the dirtiest to one of the cleanest large towns in England. He also patented a much improved knitting machine, Whitworth spring wheels to take the jolt out of steel carriage wheels, and his firm manufactured the American Hoe printing machines. Progress in the mechanical arts was perhaps his prime objective and must be regarded as true philanthropy. "I believe that the science of mechanics, though a mere material power in itself, may, if rightly used, become a moral lever, by which, like Archimedes of old, we may seek to raise the world."

Although Whitworth's education ended at age 14, he was a staunch advocate of scientific and technical education. During his life he devoted a great deal of time and money to the Manchester Mechanics Institute, Manchester School of Design, Victoria University, and was a leading member of the Institution of Civil Engineers, and the Institution of Mechanical Engineers. Perhaps his most significant act was the establishment of the Whitworth Scholarships. In a letter to Prime Minister Disraeli, in 1868, he conveyed his desire to create a permanent national endowment for scholarships of 100 Pounds each, to be used for "bringing science and industry into closer relation with each other than at present obtains in this country." Recipients were to be selected in open competition for their scientific abilities. The Whitworth Scholarship remains as a memorial to the foresight and generosity of a man who provided opportunities to many who today hold the name of Whitworth in reverence. He left over a million Pounds for the provision of schools, various institutions, public parks, and hospitals; his desire being "to establish the supremacy of reason over ignorance and the power of the human mind over the material universe."

Recognition of his enormous contributions came in many forms: various honorary degrees (when an honorary degree had meaning) from Oxford and Dublin University, the Albert Gold Medal for The Society of Arts, The Grand Prix at the Paris Exhibition in 1867, and the Legion of Honor conferred by Emperor Napoleon III. In 1869 he was created a baronet, thus, Sir Joseph Whitworth.

Other than his interests in science and mechanics, Whitworth was a simple man. His pleasures were found in gardening and farming on his estates, as well as riding. He transformed a series of unsightly quarries into beautiful parks and spent his later years near his boyhood home, preferring not to travel abroad. However, the harsh winter climate caused him to spend his last winter in Monte Carlo, where he died in 1887. As mentioned earlier, he was a man of unbending will who knew his limits, by no means narrow, and would not change his opinion when he considered it to be correct. Jane Carlyle, wife of Thomas Carlyle, described him as having a "face not unlike a baboon . . . could not invent an epigram to save his life . . . and when one talks with him, one feels to be talking with a real live man, to my mind worth any number of Whits 'that go about'." His genius was not based on fancy, but on meticulous precision, infinite pains, thorough experimentation, and rational methods. He personally supervised all of his endeavors, demanding the best in materials and workmanship, and would not tolerate less from those who worked with him. He compelled admiration from those he met; even those who did not agree with his sometimes egotistical and dictatorial character considered him "in all respects a phenomenal man". We should profit by his example. I, for one, would have been honored to have known Sir Joseph Whitworth

Leonidas M. Schwartz  
"THE NORTON OWNERS NOTEBOOK" and the above text are registered to the author, Leonidas M. Schwartz,  
Permission must be obtained in writing to reprint or use any part thereof.







I thought the Club ride was smashing. The Prez took about 20 of us on a tour of his own backyard, the hills surrounding La Honda, and the Santa Cruz Mountains. We were up, down, over, and around places I never knew existed. We descend into deep ravines filled with redwood and fern, grind up the other side to find a stunning view of the Pacific, then roam through farmland terrorizing local ducks and chickens. Carollyn Scott trailed us all on her black Roadster, collecting strays and looking for Norton parts on the highway. Trailing just about everyone, I savoured over and over again the sound of that many twins accelerating and decelerating in unison. It sounded more like a squadron of light bombers than our noble but aging English scooters.

Several of the members brought their ladies, and it was the couple in front of me that caught my eye. On their license plates were the words 2 to OZ.

What a splendid idea to copy-cat, I thought. Now that my FANG was all lacquered, had a new seat and a single Mikuni, what could be better than to crown the back with an environmental plate. My mind accelerated, and so did Norton as 6 letter possibilities appeared beneath my helmet.

At the DMV they showed me the book, all dog-eared and in two sections. First, the obvious: under N they had listed NORTON, NORTONS, NORTY, NORTON I, 2, 3, 6, and 8, NORTON M, NORTON B, NORTUN. "Oh, well," I sighed. Flashes of brilliant light: I quickly turned to the Ss to sadly find SNORTN was gone, too; so was SNORTIE, SNORTON, SNORTS, SNORTER, even SNOTTY. MY NORT had been taken, and I think I know by whom. (Could Steve be the re-incarnation of Pa Norton? What's his birth date anyway?) VRMM was gone, so was VRMMM and VRMMMM, PUDGY, YOGI BR, YATZEE, YAHOO, POWER, PULLIT, BEST MC, BEST BOD, YUMMY, and, yes, even YOWSA and YOWSAH!

A large Black gentleman fell in line behind me, waiting to view the precious tablets while humming "Just Enough for the City". I asked him if he was in a hurry. He said, "Say what." I said that SAYWHAT was already taken and giggled. He moved closer.

Quickly I began to speed-read: 2DELOO, 2THBONE, 2THOR, 2TOPOUT, 2THELMA... all gone. So were 2AFLAME, 2AWSUM, 2BOOGIE, 2BOZOS, and 2BAD4U (exactly what I thought). MXRACER, SLURPY, WICKED, R LUCK, OM, OMM, OMMM, OMMMM. "Oh no," I murmured. Clearly, I wasn't the only clever son of a bitch on this coast. "Faster," I thought and soon found NOJOKE, NOFIZZ, NOHONDA, NOPLUGS, AARF, THE OX, THE RAG. FANG was gone (Phyllis Diller, probably), and so was ASOONER, I-WASHUM, ILUVUBB, I LIKE IT, I LIKE TO, CATCH22, MUZZCAT, NOIGUN. I began to perspire and blindly raced to the Bs. Perhaps there would be one last sign. BEGLAD ("Why, yes," I nodded); BEGOD ("How?" I wondered); and then BEGONE ("You bet.") I grabbed my helmet and left.

From that day to this I have become obsessed. I know my plate is out there somewhere, only to be deciphered--perhaps a word in the Chronicle, a line from a rock and roll song, a slurred word from a passing drunk.

Sitting here late at night, I gaze out at the City, sipping gin from a coffee cup, firmly convinced my plate is coming. After all, it is 4MYEGO.

Brian Halton

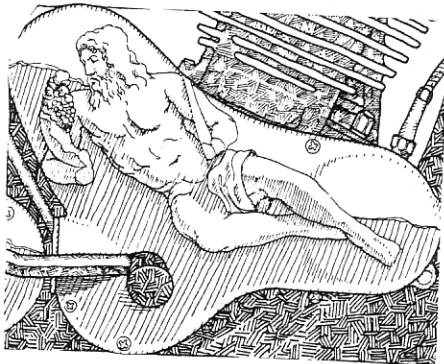



## Ron's Cycle Sales

215 LANCASTER STREET  
LEOMINSTER, MASS. 01453  
1-617-637-6191

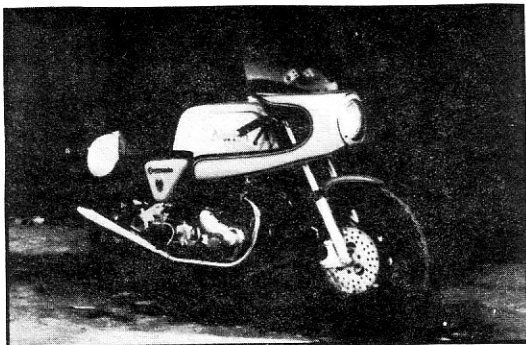

### Shop Services

Bead Blasting  
Exhaust Port Repair  
Painting  
Complete Engine Rebuilding  
Crank Grinding  
Regrind Cam Followers  
Cylinder Boring  
Engine Balancing  
Shot Peen, Magnaflux, Zyflo  
Connecting Rods Resized  
Welding, Aluminum, Steel  
Complete Restorations  
99% Factory Parts

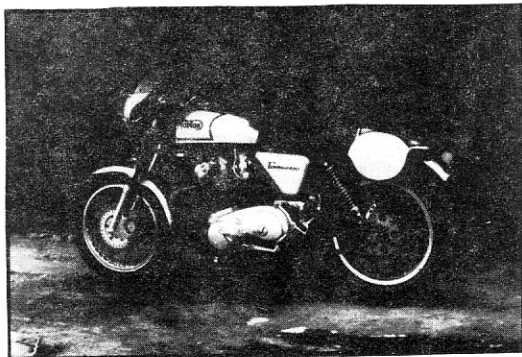

The above Norton has turned the  $\frac{1}{4}$  mile middle to high elevens, 110 to 114 mph. Shocks, Street tire, No gas additive.

### Custom Machining

Items made to date

#### TITANIUM

Valve collars  
Swing arm spindles  
Connecting rods  
Axles

#### ALUMINUM

Connecting rods  
Clutch hubs  
Swing arm  
Disc brake hubs  
Engine plates  
Foot pegs  
Instrument cases  
Exhaust flanges  
Push rods

#### STEEL

Flywheels  
Maniflows  
Brake discs  
Valves  
Spring cups  
Push rods

### HIGH PERFORMANCE PARTS

900 kits & 850 high compression pistons  
Cams (Norris-Megacycle-Combat)  
Valve springs & titanium collars  
Close ratio gears - 4 & 5 speed  
Lightened timing gears  
Racing head steadies  
Norvil fiberglass fairings  
gas tanks  
seats  
Lockheed brake parts  
Silicone brake fluid  
PLUS MORE



## TRADING POST

Current and prospective members may place Norton-related ads in the TRADING POST by writing the pertinent information in as concise a form as possible and sending it to the Editor. Ads will normally run for two months, but they may be renewed should the advertiser so desire. There will be no fee for any advertisement in the TRADING POST.

Commercial enterprises may advertise their goods and/or services in the NORTON NOTICE for a nominal fee which will help offset printing costs and thereby support the Northern California Branch of the NOC.

Commercial advertising rates are:

	1 issue	3 issues	6 issues
¼ page	\$10	\$25	\$45
½ page	\$15	\$40	\$70

Wanted: John Player Norton in very good/excellent condition. Will pay cash only.

Wanted: Interstate tank/seat combo for '72/'73 750.

Wanted: Fastback tailpiece/LH side-cover/fork ears

DAVE HOFFMAN (916) 725-8727  
7439 Apache Way  
Citrus Heights, California 95610

1974 850 Commando parts for sale. Reasonable prices. Engine parts, seat, turn signals, etc. Call Greg or Mike (408) 866-0912

FOR SALE: Norton 750 cc '71 Roadster. Combat engine, newly rebuilt. Good condition, new tires. \$1000. Call John at 591-5484.

1972 Norton Commando with Interstate Tank. Good condition. Call Richard at 564-9293 Home  
955-8320 Work

FOR SALE: 1972 Norton Commando 750 Combat Engine. Stock and strong. \$1100.00 Fred (408)289-8528 H  
(408)274-4275 W

FOR SALE: Norton Trans  
850 Electric start 1975  
90% complete. Case and internals will fit any Norton Commando. \$250/BO. I can install it or assist you if needed. Bill Sandford  
739-7714 Evenings  
734-3750 Work



### NEW HOSS CYCLE PARTS AND SERVICE

Steve Murray, co-owner of New Hoss Cycle, is an associate member of the Northern California Branch. If you're looking for "the long deal" on TIRES, TUBES, BATTERY, etc. for your Norton or Japanese bike he is the man to call. He really wants your business, and will give you a good deal.

Unfortunately, New Hoss does not service English bikes. (Yet?) However Steve hopes all you Norton fans with a Japanese bike will stop by and chat sometime. If he can do anything for you let him know.

### NEW HOSS CYCLE PARTS AND SERVICE

MIKE DORKEY  
STEVE MURRAY

1001 MAIN ST.  
CORNER OF MIDDLEFIELD  
REDWOOD CITY, CA  
366-1336

### BAVARIAN CYCLE WORKS, INC.

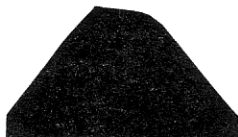

#### Accessories for the European Motorcycle Enthusiast

Albert Bar-End Mirrors  
Harro Tankbags for Nortons

Norton Belt Buckles  
Historical Motorcycle Books  
Uvex Goggles  
Belstaff Riding Suits

VDO Gauges  
Kryptonite & Maxim  
Locks  
Fiamm Horns, 6 & 12 V  
Simpson Helmets  
Rukka Rainsuits  
Thurlo Deerskin Gloves

Stop in for coffee, or send \$2.00  
for our illustrated accessory  
catalog.

BAVARIAN CYCLE WORKS, INC.  
385 8th St (corner of 8th & Harrison)  
San Francisco, CA 94103  
(415) 863-7255

# selby motors

- motorcycle sales
- self service
- accessory dept.
- complete service dept.
- machine shop
- insurance
- notary service

See Jack Morris, a branch member and Norton enthusiast for quite a few years, if you're looking for parts or accessories. Jack's got the goodies and will take the time to make sure you get exactly what you need.

Selby's service department is in the able hands of Alan Hook, an experienced Norton mechanic and also a branch member. If the Nort isn't running right and you're unsure about what to do, take it to Alan and he'll see that it gets back into tip-top shape.

346 El Camino Real  
Redwood City, Ca. 94062

(415) 369-4112



## T. T. Motors

2800 Adeline • Berkeley, CA 94703  
(415) 845-8235

NORTON ENTHUSIASTS: We specialize in Early and Late Commando Parts, and we offer a complete Service and Machine shop for your Norton work.

STOP BY AND VISIT - CHECK THESE ITEMS OUT!

- \* COMPLETE LINE OF BRITISH TOOLS
- \* NEW BLACK ROADSTER TANKS
- \* FACTORY WORKSHOP MANUALS: MKII & MKIII
- \* COMPLETE GEARBOXES, CASES AND GEARS
- \* SPEED EQUIPMENT:
  - MEGACYCLE AND NORRIS CAMSHAFTS
  - PM RACING VALVE SPRINGS AND GUIDES
  - BRANCH RACING VALVES
  - SINGLE MIKUNI KITS
- \*SERVICE DEPARTMENT--BUILDING AND MODIFICATION OF STREET AND RACING MACHINES:
  - EXHAUST PORT REPAIR
  - VALVE JOBS
  - CYLINDER BORING
  - HEAD MILLING AND SURFACING
  - MAGNAFLUX
  - AND MUCH, MUCH MORE!!!
- \*FINALLY WE OFFER A 10% DISCOUNT ON ALL NORTON PARTS TO MEMBERS OF THE NORTON OWNERS CLUB (Service work is not included)

## MOTORCYCLES UNLIMITED

Sales and Service

ALEX S. MCLEAN  
OWNER

(415) 924-0327  
8776 PARADISE DRIVE  
CORTE MADERA, CA. 94925

Motorcycles Unlimited is the West Coast distributor for Dunstall.

Complete stocklists for:

### Dunstall

Rear Sets	Valve Springs
Silencers	2-1-2 Center Std
Gas Tanks	Clip-ons
Cylinder Heads	Oil Feed Line
Front Fenders	G.T. Fairing
	Replacement
	Windshields

Plus a full supply of stock Norton bits.

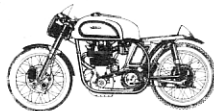

Classic Nortons on display.

LARRY RANDALL

English Specialist

## West Bay Cycle Dismantlers, Inc.

ENGINE REBUILDING & MACHINING FACILITIES  
USED PARTS & ACCESSORIES  
USED MOTORCYCLES

750 San Antonio Road  
Palo Alto, California 94303

(415) 494-8033

10% DISCOUNT TO NOC MEMBERS ON  
ALL NEW AND USED PARTS. A DEAL!

Larry Randall and Jan Barton are good people to know. At WEST BAY they have many used Norton parts at reasonable prices, as well as the expertise to help you solve any tricky problems that come up the next time you try to do some repair job. They are definitely the first people to call if you live on the peninsula and don't have the part you need, or the foggiest idea how to put the old Nort back together again.