

# Norton Notice

THE NEWSLETTER OF THE NORTHERN CALIFORNIA BRANCH

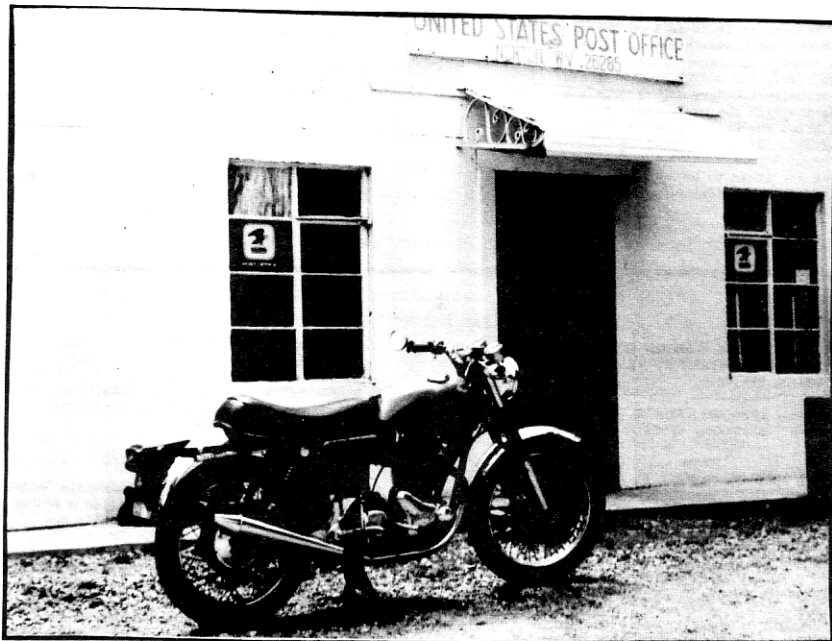

Norton

OWNERS  
CLUB

NO. 86 JUNE 1985



## Norton Notice

The Newsletter of The Northern California Branch

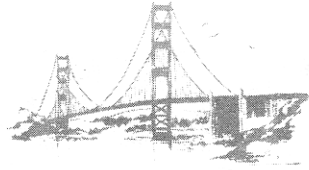

is published monthly by the NORTHERN CALIFORNIA BRANCH OF THE NORTON OWNERS CLUB. Its purpose is to inform and entertain members regarding all aspects of the Norton motorcycle, including history, technical advice, and preservation of the marque.

NORTON NOTICE is a reflection of its readership, who are encouraged to submit any article, technical tip, photograph (original or otherwise), as long as it is in good taste, so that other Norton enthusiasts may enjoy it. For Branch members who cannot attend club meetings or club rides, the NORTON NOTICE affords an opportunity to share experiences and information with the membership of the Branch, and to bring the Branch members closer together.

Deadline for items to be submitted for publication is the 21st of each month.

### PRESIDENT

Scott Marburger  
639 Kinglet Ave.  
Livermore, Ca. 94550  
(415)455-8776

### SECRETARY/TREASURER

Phil Radford  
1020 Ellis Ave.  
San Jose, Ca. 95125  
(408) 293-4548

### NORTON NOTICE EDITOR

Tom Mullen  
1930 Almaden Rd. #45  
San Jose, Ca. 95125  
(Mail in advertisements;  
do not call them in)

### RIDE ORGANIZERS

Tom Dabel (408)272-0369  
Mike Hansen (415)969-2489

### PARAPHERNALIA

Tom Borman  
427B 25th. St.  
San Francisco, Calif.  
94114

MEMBERSHIP IN THE NORTHERN CALIFORNIA BRANCH OF THE NORTON OWNERS CLUB IS AVAILABLE FOR \$25.00 PER YEAR.

MEMBERSHIP DUES ARE PAYABLE TO THE BRANCH SECRETARY/TREASURER, WHOSE NAME IS SHOWN ABOVE.

RENEWAL DUES ARE PAYABLE AT THE END OF THE INDIVIDUAL'S MEMBERSHIP YEAR, THAT MONTH BEING DESIGNATED BY THE LAST NUMBER OF THE INDIVIDUAL'S MEMBERSHIP NUMBER AS LOCATED ON THE MAILING LABEL OF THE NORTON NOTICE OR THE MEMBERSHIP CARD. FOR EXAMPLE, 745/2 DENOTES MEMBER NUMBER 745 WITH DUES EXPIRING ON THE 1st OF FEBRUARY.

ALL CHANGES OF ADDRESS SHOULD GO TO THE BRANCH SECRETARY/TREASURER, NOT THE NORTON NOTICE EDITOR.

Subscription to the NORTON NOTICE only is available for \$15.00 per year. This does not include membership in the NORTHERN CALIFORNIA BRANCH of the NORTON OWNERS CLUB, nor does it afford any of the rights or privileges of membership in the NOC.

Membership in the NORTHERN CALIFORNIA BRANCH of the NORTON OWNERS CLUB entitles a member to monthly issues of the NORTON NOTICE and bi-monthly issues of ROADHOLDER magazine, which is sent directly from England, keeping members informed of Norton owners' activities worldwide. Membership provides voting privileges at all NOC and Branch meetings, and allows one to purchase Norton spares directly from England, at significant savings, through the NOC Spares Program.

The cover bike is owned by Jeff Michael of Fairmont, W.V. I do not have any information on the bike, Jeff submitted the photo along with an article which was published in the February issue of the N/N.



## PUT UP OR SHUT UP

I have been informed that unless I receive more material for the N/N, the format will have to be changed to possibly a bi-monthly publication. As with all things, finances are a major consideration. I have combined my column for last month with this months, I usually would rather dedicate the space to input from the members, but since it is not coming, I shall indulge myself. All classifieds will run for one month unless otherwise noted.

I would like to add to Phil's list of new laws in the April issue. The first being that anyone found guilty of speeding in excess of 100 m.p.h. will have their license suspended for a specified period, automatically! I gleaned this following piece from a local paper. Lane splitting is not a violation of the California Vehicle Code. C.H.P. and S.J.P.D. both say you can be cited if you travel more than 10 m.p.h. faster than the flow of traffic or if you weave between two lanes. Apparently if this is performed at any speed over 40 m.p.h. you are also held liable and accountable. The article continues and includes five rules and reasons as to why one should not, which are actually only common sense. One last item, when coming to a stop sign, one is required only to come to a complete stop. You are not required to dab a toe, foot or knee to be within the law. As the cop that I talked to put it, "If you're slick enough to do it, go for it." This applies to any situation where one is required to come to a full and complete stop.

About the 100 m.p.h. law, everyone with 85 m.p.h. speedos should take note and keep it under 99 m.p.h.

Ed Brooks has just returned from two weeks in England and a tour of the National Motorcycle Museum, the magazine that he brought back is enough to make any Anglophile hock the kids braces for the airfare. He also rode the rotary Norton, so , anyone wanting to hear how the NEW NORTON runs, stop by and talk to Ed, I'm sure he will be more than glad to share his experiences, Ed is always great talking to.

Sorry to say it but I screwed up by the numbers in the May issue, COMPLETELY left out the ride to Moro Bay, I apologize to all that I have inconvenienced, at the next meeting feel free to to charge a pint to Henry, he owes me a few. Tom Dabel has resigned as co-ride marshal, Mike Hansen now has full charge of planning. Ricks place in Palo Alto has been sold consequently a new location must be found. Art Sirota is looking into a new location.

A word of warning, watch out while on the Skyline, there are cops EVERYWHERE, see you at the Pinnacles,

*Beer*

Welcome to the club the following new members

Jim Price	Soquel, Calif.
David Frederick	Bakersfield, Calif.
Ralph Glorioso	Santa Rosa, Calif.
Jeff Schulz	Warren, Michigan
Jim Meads	Boulder Creek, Calif.
Dale Sherman	Portland, Oregon
Dave Henschmidt	Alameda, Calif.
Charles Bulkley	Oakland, Calif.
John Dirickson	Tempe, Arizona
John Ferrara	San Jose, Calif.

There will be no columns from Scot or Phil this month.



9th ANNUAL Owners Club Picnic &

# Norton

Old Timers  
Motorcycle  
Meet

**SUNDAY JULY 21st 1985**

SAN MATEO COUNTY MEMORIAL PARK  
HUCKLEBERRY FLAT PICNIC AREA #2  
(HALF A MILE WEST OF MAIN PARK  
ENTRANCE ON PESCADERO RD.)

**ACTION BEGINS AT NOON**  
ALL NORTON RIDERS AND  
**EARLY NORTONS**  
**ESPECIALLY WELCOME!**



SPONSORED BY  
NORTHERN CALIFORNIA BRANCH  
NORTON OWNERS CLUB

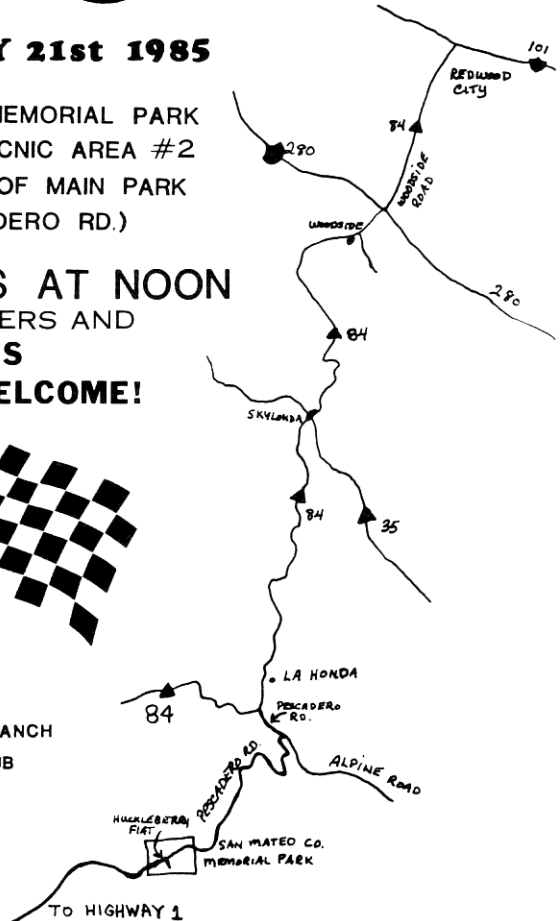

**Hot Dogs & Soft Drinks Available - No Beer Supplied**

FOR MORE INFO, CALL SCOTT (415) 455-8776



## UPCOMING EVENTS

June 9 - E.M.A. swap meet, Vacaville Gliderport.

June 13 - "The Class Reunion", 2700 El Camino Real, Palo Alto.  
Page Mill Rd. & El Camino Real. N.W. corner of the intersection.  
7:00 p.m.

June 23 - Marin County ride, finishing up at Cathy & Bernie Birleff's place.

July 11 - meeting at Edinburgh Castle, S.F.

NOTICE : In the event of rain on the day of a club ride, the ride is automatically postponed one week. Also, riders should have plenty of oil and gasoline by the scheduled departure time and all personal problems should be taken care of. In other words...

FULL TANKS AND EMPTY BLADDERS .

**750cc**

**BERLINER**  
MOTOR CORPORATION  
Hasbrouck Heights, New Jersey

**COMMANDO**

**Norton** To ride the new Norton Commando 750 OHV is to experience the thrill of superior cycling performance.



# Norton Notice

these  
 T-SHIRTS T-Shirts are only available in large.  
 BASEBALL  
 JERSEY

All branch logo t-shirts are white, baseball jerseys are white with blue sleeves.

All t-shirts are Hanes Beefy T's  
 Prices : T-shirts (all) \$8.00  
 : Baseball Jerseys \$9.50  
 Pay by check made payable to the  
 "Norton Owners Club"

## T-SHIRTS\*\*\*T-SHIRTS\*\*\*T-SHIRTS\*\*\*

### NOC BIG N LOGO

	S	M	LG	XLG
BLACK	*	*	*	*
NAVY	*	*	*	*
YELLOW/BLACK	*	*	*	
WHITE/BLACK		*	*	

### BRANCH LOGO

### NORTHERN CALIFORNIA BRANCH TOOL LOAN-OUT PROGRAM

Get in touch with Harry Bunting if you need one or more of the following tools for working on your bike. A refundable deposit equal to the replacement value of the tool is required at the time you pick it up.

TOOL	DEPOSIT
timing cover oil seal guide.....	\$ 5.00
rocker spindle puller.....	\$25.00
crankshaft sprocket puller.....	\$12.00
clutch spring tool.....	\$12.00
clutch locking tool.....	\$18.00
valve spring compressor.....	\$22.00
exhaust nut "C" spanner.....	\$10.00
timing pinion extractor.....	\$20.00

Harry Bunting (415) 968-2020  
 1401 Gilmore St.  
 Mountain View, Ca. 94040

### PARAPHERNALIA

4 1/2" sticker	N.O.C.	\$1.00
2" sticker	N.O.C.	\$.50
2 1/2" x 3 1/2" N.O.C. sticker		\$.75
( red, white, and blue )		
N.O.C. keyfob		\$1.50
4 1/2" embroidered patch		\$2.50
Lapel pin, branch logo		\$1.25
T-shirts - N.O.C. and branch various sizes and colours call or write for details. Tom Borman		
4278 25th. St. San Francisco, Ca 94114 415-282-9304		

### NEW PARAPHERNALIA

Black T-shirts, "MY SUCCESS IS DUE TO MY UNAPPROACHABLE NORTON."  
 Size XL ( US large ) only. \$8. plus shipping, \$ 1.50.

Norton Owners Club Commando Service Notes.

45 pages of technical information produced by the N.O.C. England. Invaluable information to any Commando owner. \$ 5. plus .75¢ postage.

John Player Norton key fob	\$ 1.75
N.O.C. embroidered patch 1 1/2" sq.	\$ 1.50
"Unapproachable Norton " decal 1 x 2 1/2"	\$ 1.00
N.O.C. machine badge 3" x 3"	\$ 6.00
John Player Norton lapel pin	\$ 1.50

On items listed above, please include an appropriate amount extra to cover postage and an envelope, thanks Tom.



ILLUSTRATIONS: BARRON STOREY



## MY FIRST NORTON CLUB RIDE

by Margie Siegal

Learning that we were all supposed to saddle up and present ourselves at a specified time and place for the club ride to the Visalia Antique Rally, I duly arrived at said time and place to find Robert Briscoe, Dave Cronin and myself the only members who bothered to turn out. After the requisite amount of shoptalk, we proceeded down IOI and then east on Highway 25. We stopped in Hollister for lunch. The sight of parked Nortons attracted a swarm of other Eurobikers headed in the same direction, including Pat Highsmith on his Vincent, and the ten of us who finally collected at the same table nearly gave several older people in the cafe heart attacks. I guess we looked tough or something. After a motion to take over the town in memoriam to the crazies of 1947 failed, we again set out upon the road. Highway 25 is noted for its wide sweepers, pretty scenery and lack of gas stations, important when you own a Roadster. For thirty miles, the scenery was wasted on me as I strained my eyes in vain for the sight of a pump. Robert and Dave stopped for a breather, but I kept on going, worried that I would not be able to restart the bike. The trip meter read II2, the reserve tank was empty, the engine was coughing and I went around a bend, saw a GAS STATION, shouted THANK YOU LORD\*\* and the engine quit. I have never so happily pushed a bike. The rest of the trip was pretty uneventful

Visalia was a great deal of fun. There were lots of interesting and unusual bikes, friendly people and interesting stuff to swap, although I heard a lot of complaints about high prices. Phil Radford showed up with a truckload of stuff to sell, Art Sirota showed up with a truckload of bikes to show and Tom Dabel and Jan Barton showed up with a truck. I suggest that people show up at swapmeets on bikes. That way you don't get tempted to spend huge amounts of money on stuff that will further clutter your garage.

The Southern California Norton Club gave out prizes for the best Nortons. Art Sirota's 1948 rigid frame won second place, not too shabby where first place was won by Brian Slark's Dommie. I would have won the prize for the longest distance female rider if I had entered my bike in the show. I didn't because a ) I'm too cheap to hand over fifteen bucks entry fee b ) my Roadster also qualified for least remarkable Norton and most overlooked bike. I have owned my Nort for six months now and it has proved suprisingly reliable ( knock on lots of wood ). I'm planning several longer trips this summer. June 9 is the European Motorcycle Association rally in Vacaville and it would be nice to see a larger variety of Nortons up there.

### SUGGESTION BOX

Some of us were not born with a silver spanner in mouth, but would like to learn more mechanics. If there is enough interest, someone could hold a class on Norton fixing during the winter months when it's too cold and wet to do much riding anyway. I suggest as topics valves and rings and how to make friends with your clutch.

MARGIE

### TECH TIP

Those of you with Nortons having either front or rear drum brakes can improve performance for very little money the next time you install new shoes or re-line the old shoes. Take the new shoes or newly re-lined shoes and the brake drum down to a machine shop that has an arcing machine and have the shoes arced to fit the drum. If you take both the front and rear drums and shoes down with you, be sure not to mix up the sets. That is , keep the shoes and the drum they go in together. Don't get the front shoes accidentally arced to match the rear drum! I found a shop in Belmont called Flanagan's who will arc one pair of shoes to fit your drum for only \$3. Their address is 794 Old County Rd. and the phone number is 595-5400. They do an expert job and the difference in braking ability is dramatic.

Art Sirota



## PLATE. Y.

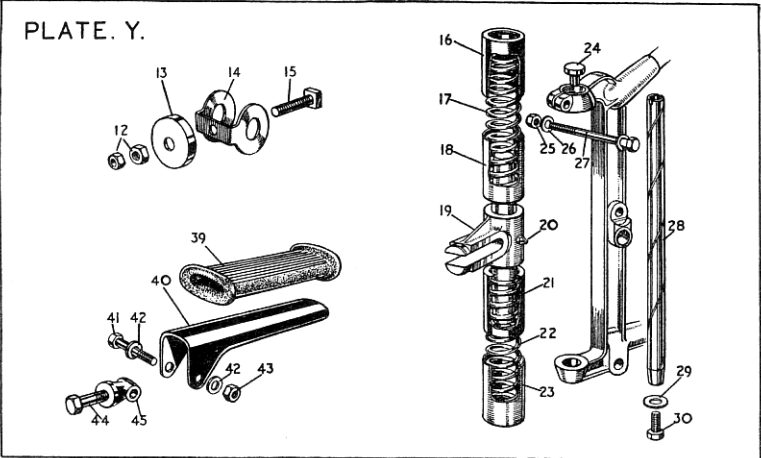

More N/N definitions, not necessarily by Webster

A historical addition for the serious collector..... makes a nice planter box  
Any help or information on this Norton will be greatly appreciated..... what have I gotten myself into ?

Would make excellent Atlas front fender if it was chromed..... no way it will fit on anything you might have

You won't believe the condition it's in.... only the gullible need inquire  
Pink slip has been misplaced..... if you even call me about this one, I've also got a little bridge in Brooklyn that I can let you have real cheap

Exhaust port threads in good cond..... all the fins have been broken off  
No broken fins..... both exhaust ports are stripped  
Front fender has a wrinkle..... bike recently smashed into a brick wall at 80 m.p.h.  
Will pay your price..... I'm desperate and will sign over my first born male child  
Only 110 miles on the odometer..... needs speedo cable  
Only 50 miles since complete rebuild..... hasn't run in years

Could use a little aesthetic work..... accidentally got tossed in the crusher at the wrecking yard

95% complete..... engine and frame missing

Runs strong..... engine turns freely

Must see to appreciate..... come look at it only if you want to get a good hosing

Comes with lots of spares..... couldn't figure out how to put it all back together again

thanks again to Art.

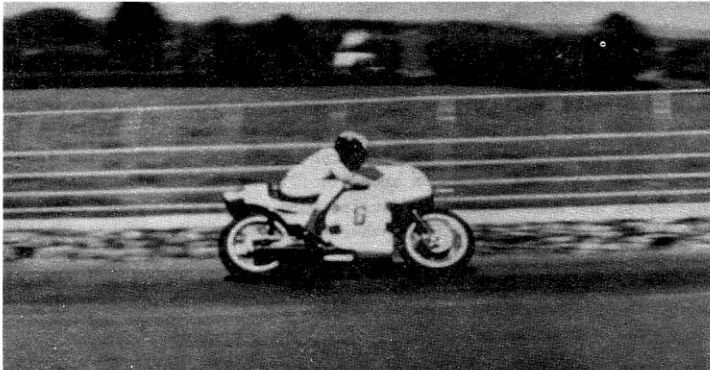





**FOR SALE**

B.S.A. Gold Star DBD34 Clubman, 6 gal. Lyta tank, Borrani rims & stainless spokes, Lucas racing magneto, John Tickle TLS front brake, Cerriani road race forks. \$2500 Phil.  
(408) 293-4548

## Norton

# SERVICE BULLETIN

TRIUMPH NORTON INCORPORATED • P.O. BOX 275 • DUARTE, CALIFORNIA 91010

Number: 10/74  
 Subject: Improved Exhaust  
 Pipe Mounting  
 Models: All  
 Date: December 1974

IMPROVED EXHAUST PIPE MOUNTING FLANGE

A new design exhaust pipe was introduced on Norton Commando 850 models starting with engine number 317312.

ASSEMBLY SEQUENCE

The new exhaust pipe mounting flange is a tapered self-aligning seat. A tapered seat is inserted into the exhaust port, then the tapered seat exhaust pipe, and finally a matching tapered ring. The finned lock nut is then screwed into the exhaust port as with the earlier design. The lock nut tab washer is no longer used.

REQUIRED PARTS

To install the latest design exhaust pipes the following parts are required:

1 off	065256 Exhaust pipe	(R.H.)	Mk. 2A
1 off	065257 Exhaust pipe	(L.H.)	Mk. 3
1 off	065464 Exhaust pipe	(R.H.)	Mk. 2 R.S.
1 off	065465 Exhaust pipe	(L.H.)	Mk. 2 R.S.
1 off	065466 Exhaust pipe	(R.H.)	Mk. 2 I.S.
1 off	065467 Exhaust pipe	(L.H.)	Mk. 2 I.S.
2 off	065259 Tapered seat		} All
2 off	065260 Tapered collet		
1 off	066332 Cross tube		

Ref. N3/77



# Hall-Burdette

MOTORCYCLES



MOTO GUZZI

DUCAATI

We have been selling and servicing Nortons since 1948 and have a good supply of parts and accessories, both new and used. Our mechanic, Bob Bennett, has been repairing Nortons for over 20 years and is a recognized expert. Thor Berke, our parts manager, has a thorough familiarity with all Norton parts and accessories.

2010 DEL PASO BLVD.  
SACRAMENTO, CALIFORNIA 95815  
PHONE (916) 825-1797

RABER'S

EUROPEAN CYCLE WORKS, INC.

"Your source for parts and service"

BSA

The Unapproachable

TRIUMPH



DUCAATI

MOTO GUZZI

the same old guys at the same old place...

Over 60 years combined M/C knowledge...  
( Bill must be older than I thought )

\*\*\*\*\*PARTS: Bob Raber  
SERVICE: Bill Mankins\*\*\*\*\*

1615c ALMADEN ROAD (rear building)  
SAN JOSE, CALIFORNIA. 95125  
(408) 998-4495



# T.T. MOTORS

Norton Owners - T.T. specializes in European motorcycles and offers complete parts, service, and machine shop for all the wonderful bikes we sell.

Stop by and visit and check us out!

- \* Complete line of British tools
- \* Manuals and spares for your Norton
- \* Speed Equipment:

Megacycle and webcam camshafts  
Single Mikuni kits  
Exhaust port repair \$45 each  
Valve jobs and port work  
Cylinder boring and surfacing

- \* 10% discount on all parts (except Lucas) to N.O.C. members

2800 Adeline Street  
Berkeley, CA 94703  
9 a.m. - 6 p.m. Tues. - Sat.

845-8235



MOTO GUZZI



# MUNROE MOTORS, INC.

MOTORCYCLES

SALES - SERVICE - PARTS

Munroe has three mechanics that are familiar with Nortons and have been for a number of years. We can replace exhaust ports with the head on the bike and don't know of anyone else who can. The job looks like original factory! Call for a quote on shop prices. We also have a good Norton parts supply.



INC.

412 VALENCIA ST.  
SAN FRANCISCO 94103  
PHONE 626-3496